

PART NO.
660500TP051
DWG NO.
C6605TP

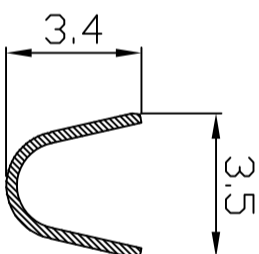

SEC A-A

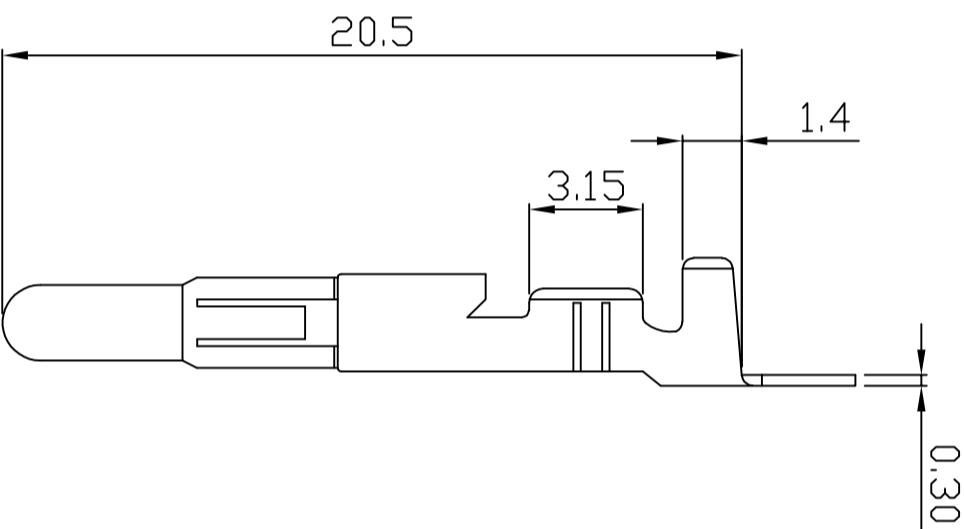
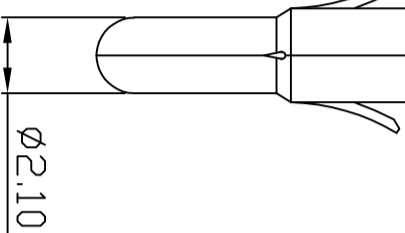
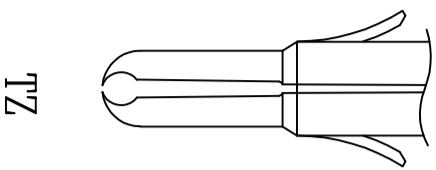
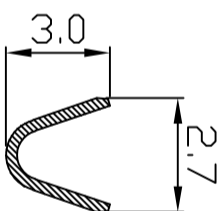

SEC B-B

- NOTE:
1. Terminal Material: See table
 2. Plated: Ni 25u"min Tin-plated 50u"min.
 3. Insulation O.D.: 1.0~2.1
 4. Applicable wires: #24~#18
 5. Q'ty / reel: 7,000pcs

No.	Part No.	Material	Finish
1	660500TZ051	Brass	Tin pre-plated
2	660500TP051		
3	660500TZ351	phosphor	
4	660500TP351		

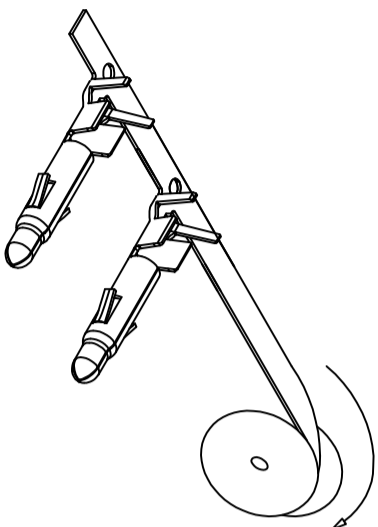
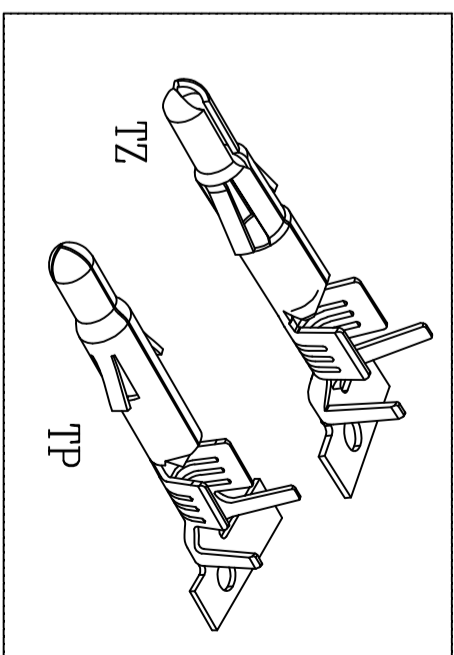

REV.	REVISION	UNIT	DIS	DATE	UNLESS OTHERWISE SPECIFIED TOLERANCES
					3 PLACE ±0.5 ±0.10
					2 PLACE ±1.5 ±0.25
					1 PLACE ±2.0 ±0.50

EXCON

EXCON TECHNOLOGY COMPANY

SCALE	REV.	PAGE	UNIT	DWG NO.	PART NO
NONE	B	1	TYRD ANGLE PROJECTION	C6605TP	660500TP051

