

PART NO.
660500TB051
DWG NO.
C6605TB

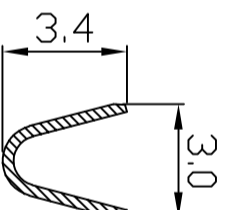

- NOTE:
1. Terminal Material: See table
 2. Plated: Ni 25u"min Tin-plated 50u"min.
 3. Insulation O.D.: 1.7~3.0
 4. Applicable wires: #18~#14
 5. Q'ty / reel: 3,000pcs

No.	Part No.	Material	Finish
1	660500TB051	Brass	Tin pre-plated
2	660500TB351	phosphor	

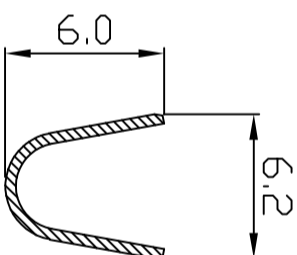
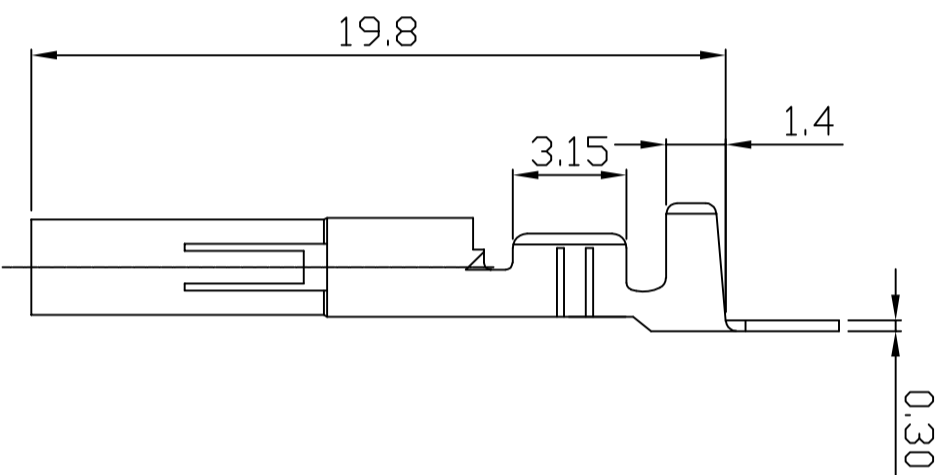
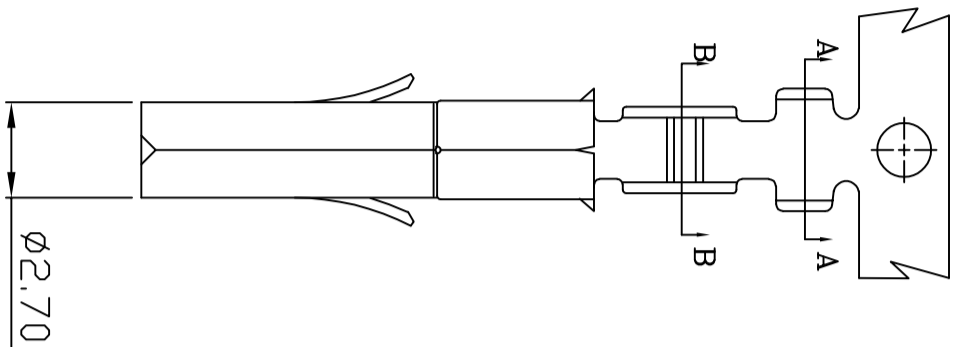
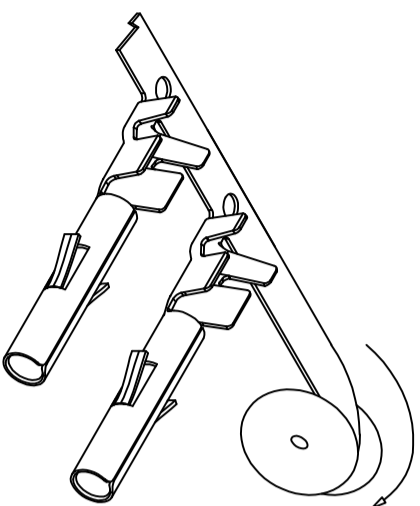
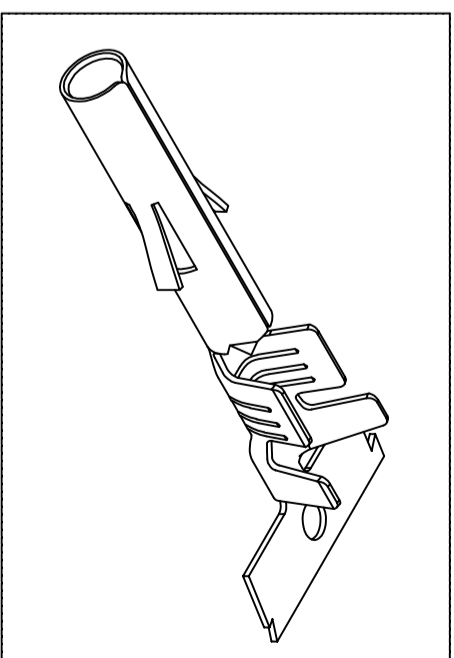

UNLESS OTHERWISE SPECIFIED TOLERANCES
 3 PLACE ± 0.5 ± 0.10
 2 PLACE ± 1.5 ± 0.25
 1 PLACE ± 2.0 ± 0.50

EXCON

EXCON TECHNOLOGY COMPANY

REV.	REVISION	UNIT	DIS	DATE
SCALE	REV.	PAGE	TYRD ANGLE PROJECTION	
NDNE	B	1		

DWG NO:	PART NO
C6605TB	660500TB051