

PART NO.  
8803xxHB001  
DWG NO.  
C8803HB

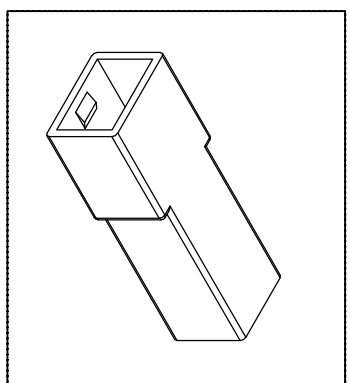
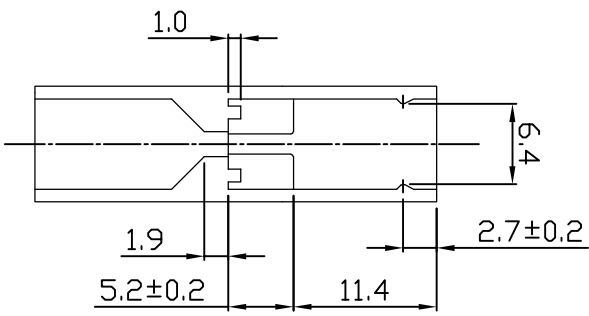
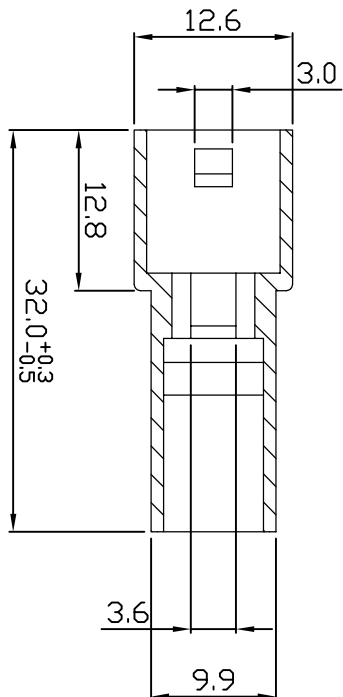
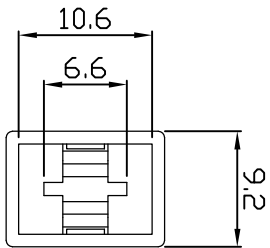

NOTE:

1. Housing Material: Nylon 66 UL 94V-0
2. Insulation resistance: 1000M ohm/min.
3. Withstand voltage: 600V AC/minute.
4. Current rating: 5A AC/DC.

REV.	REV.	REVISION	UNIT	DIS	DATE	DWG NO:	PART NO
5/1	A	1	THIRD ANGLE PROJECTION			C8803HB	8803xxHB001
UNLESS OTHERWISE SPECIFIED TOLERANCES						EXCON TECHNOLOGY COMPANY	
3 PLACE ±0.5 ±0.10							
2 PLACE ±1.5 ±0.35							
1 PLACE ±2.0 ±0.50							
ANGLE DIM							
SCALE							

