

PART NO. 660500TPxxx
 DWG NO. C6605TP

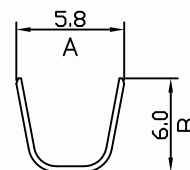

TA/TD/TP

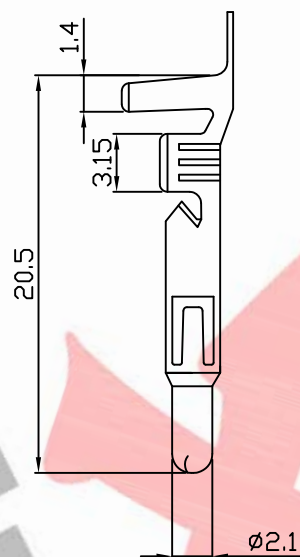
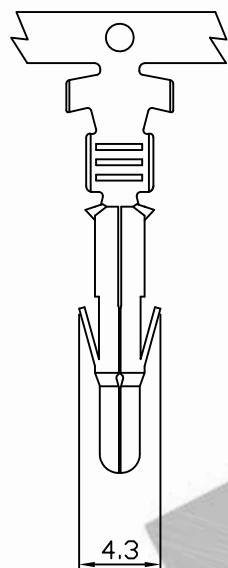
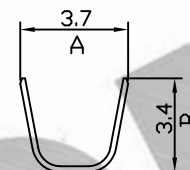

TU/TE/TZ

SEC A-A

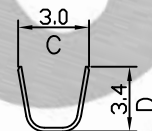

TA/TD/TP

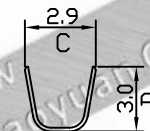

TU/TE/TZ

SEC B-B

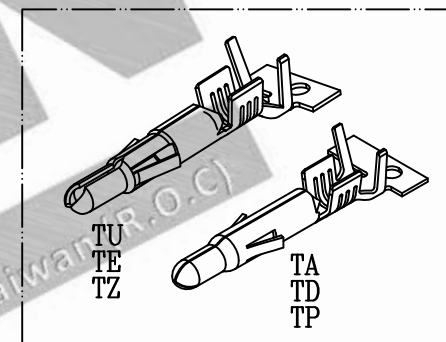

卷盤收料方向

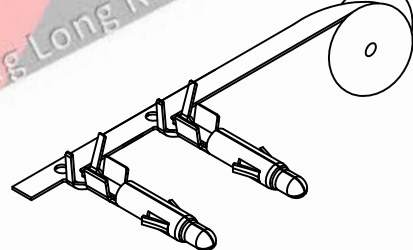

NOTE 1 :

1. Terminal Material: Brass bronze or Phosphor
2. Plated: Ni 25u"min Tin-plated 50u"min.
3. Applicable wires: See table
4. Q'ty / reel: See table

No.	Part No.	DIM (mm)				Wire Range	Insulation O.D.	Material	Finish	Q'ty/reel
		A	B	C	D					
1	660500TA051	5.8	6.0	3.0	3.4	AWG#18~#14	3.3-5.08mm	Brass	Pre-plated tin	3,000pcs
2	660500TD051	4.1	4.6	3.1	3.6	AWG#20~#14	3.3-5.08mm			4,000pcs
3	660500TP051	3.7	3.4	2.9	3.0	AWG#24~#18	1.0-2.5mm	phosphor	Pre-plated tin	7,000pcs
4	660500TA351	5.8	6.0	3.0	3.4	AWG#18~#14	3.3-5.08mm			3,000pcs
5	660500TD351	4.1	4.6	3.1	3.6	AWG#20~#14	3.3-5.08mm	Brass	Pre-plated tin	4,000pcs
6	660500TP351	3.7	3.4	2.9	3.0	AWG#24~#18	1.0-2.5mm			7,000pcs
7	660500TU051	5.8	6.0	3.0	3.4	AWG#18~#14	3.3-5.08mm	phosphor	Pre-plated tin	3,000pcs
8	660500TE051	4.1	4.6	3.1	3.6	AWG#20~#14	3.3-5.08mm			4,000pcs
9	660500TZ051	3.7	3.4	2.9	3.0	AWG#24~#18	1.0-2.5mm	Brass	Pre-plated tin	7,000pcs
10	660500TU351	5.8	6.0	3.0	3.4	AWG#18~#14	3.3-5.08mm			3,000pcs
11	660500TE351	4.1	4.6	3.1	3.6	AWG#20~#14	3.3-5.08mm	phosphor	Pre-plated tin	4,000pcs
12	660500TZ351	3.7	3.4	2.9	3.0	AWG#24~#18	1.0-2.5mm			7,000pcs

UNLESS OTHERWISE SPECIFIED TOLERANCES
 3 PLACE ±0.5 ±0.10
 2 PLACE ±1.5 ±0.25
 1 PLACE ±2.0 ±0.50
 ANGLE DIM

EXCON
 EXCON TECHNOLOGY COMPANY

REV.	REVISION	DIS	DATE	SCALE	REV.	PAGE	UNIT	MM	DWG NO:	PART.NO
				3/1	A	1	THIRD ANGLE PROJECTION		C6605TP	660500TPxxx