

PART NO. 5090xxHA001
 DWG NO. C5090HA

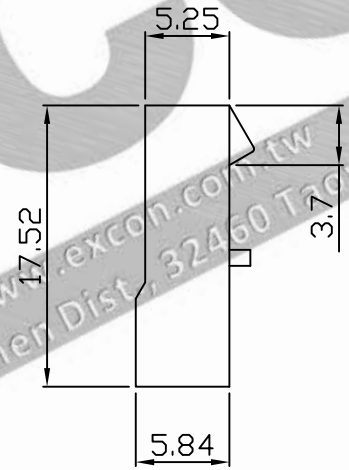
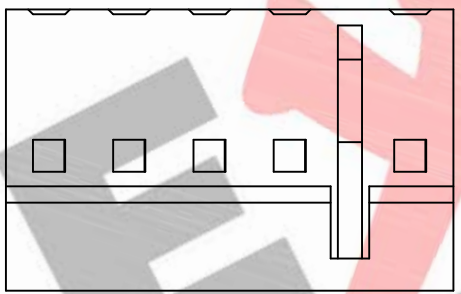
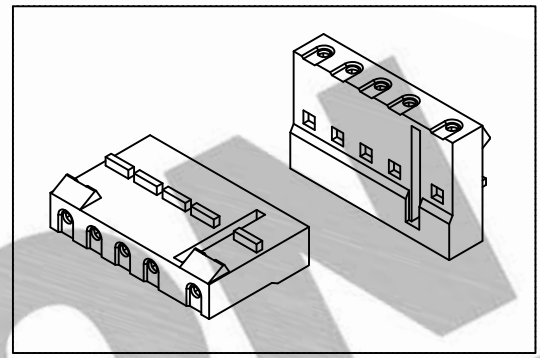
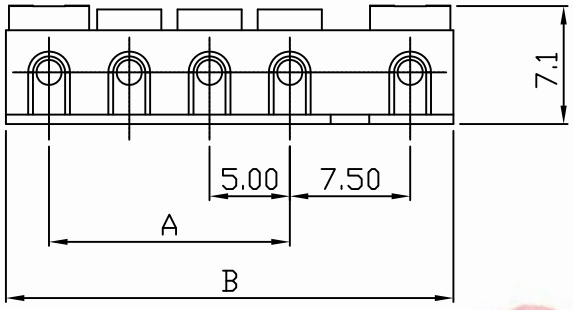

Dimensional & Ordering Information:

Part No.	Circuits	Dim A	Dim B
509001HA001	1	--	5.38
509002HA001	2	--	12.88
509003HA001	3	5.00	17.88
509004HA001	4	10.00	22.88
509005HA001	5	15.00	27.88
509006HA001	6	20.00	32.88
509007HA001	7	25.00	37.88
509008HA001	8	30.00	42.88
509009HA001	9	35.00	47.88
509010HA001	10	40.00	52.88
509011HA001	11	45.00	57.88
509012HA001	12	50.00	62.88
509013HA001	13	55.00	67.88
509014HA001	14	60.00	72.88
509015HA001	15	65.00	77.88

NOTE:

1. Housing Material: Nylon 66 UL94V0
2. Insulation resistance: 1000M ohm/min.
3. Withstand voltage: 1500V AC/minute.
4. Current rating: 9A AC/DC.
5. Voltage rating: 250V AC/DC

UNLESS OTHERWISE SPECIFIED TOLERANCES			
3 PLACE ±0.5 ±0.10			
2 PLACE ±1.5 ±0.25			
1 PLACE ±2.0 ±0.50			
ANGLE DIM			
REV.	REVISION		DIS DATE
SCALE	REV.	PAGE:	UNIT mm
1/1	A	1	THIRD ANGLE PROJECTION

EXCON
 EXCON TECHNOLOGY COMPANY

PART.NO
 5090xxHA001