

PART NO. 508200TC051
 DWG NO. C5082TC

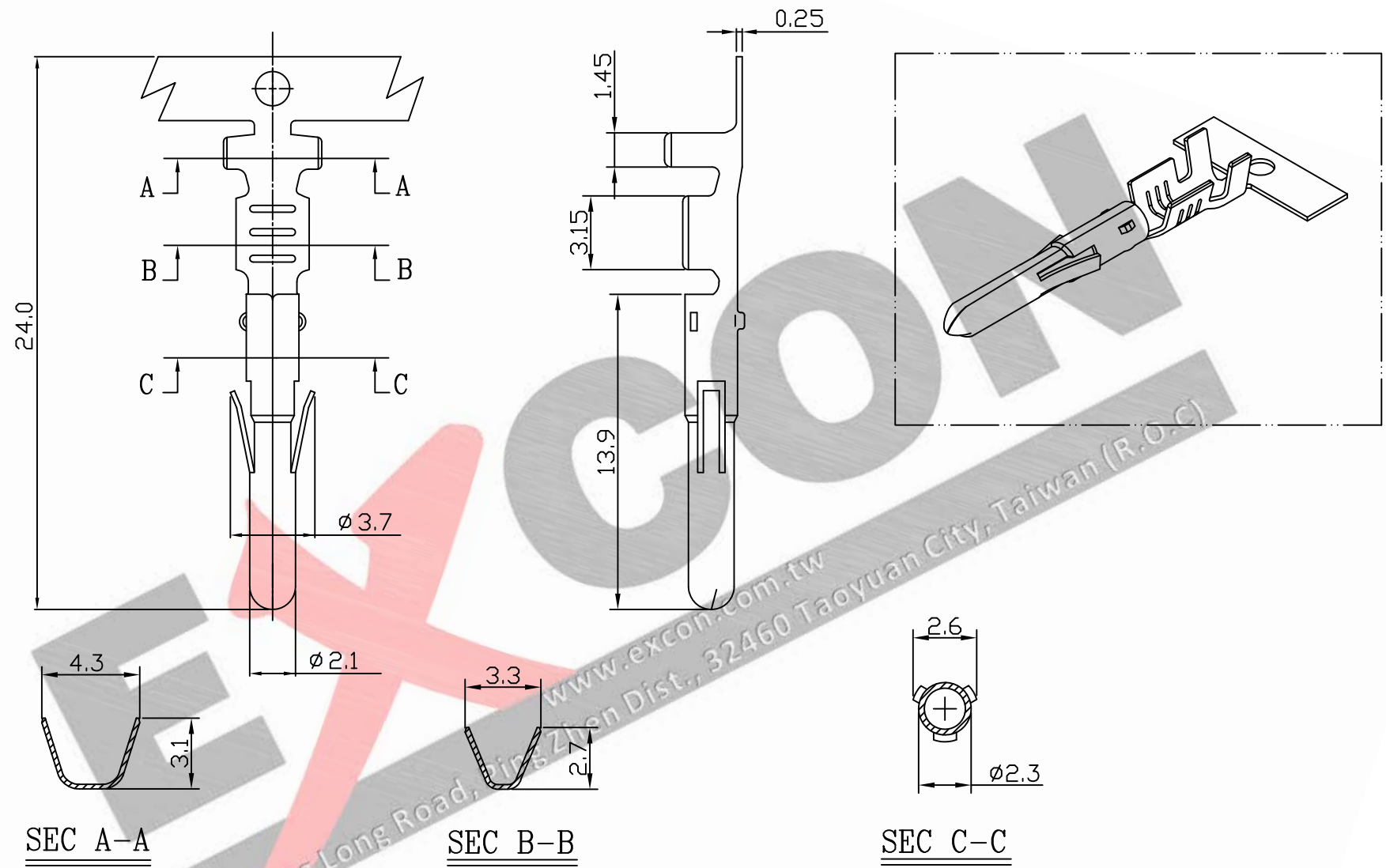

SEC A-A

SEC B-B

SEC C-C

NOTE:

1. Terminal Material: Brass bronze
2. Plated: Tin-plated 50u"min.
3. Applicable wires: AWG#18-#24
4. Insulation O.D.: 1.3-2.5mm
5. Q'ty/reel: 7,000pcs

| | | | | | | |
|-------|----------|-------|------------------------|---------------------------------------|-------------|---------------------------------|
| | | | | UNLESS OTHERWISE SPECIFIED TOLERANCES | | EXCON |
| | | | | 3 PLACE ±0.5 ±0.10 | | |
| | | | | 2 PLACE ±1.5 ±0.25 | | <u>EXCON TECHNOLOGY COMPANY</u> |
| | | | | 1 PLACE ±2.0 ±0.50 | | |
| REV. | REVISION | | | DIS | DATE | ANGLE DIM |
| SCALE | REV. | PAGE: | UNIT | mm | | DWG NO: |
| 4/1 | A | 1 | THIRD ANGLE PROJECTION | | | C5082TC |
| | | | | | PART.NO | |
| | | | | | 508200TC051 | |

PART NO. 508200TC351
 DWG NO. C5082TC

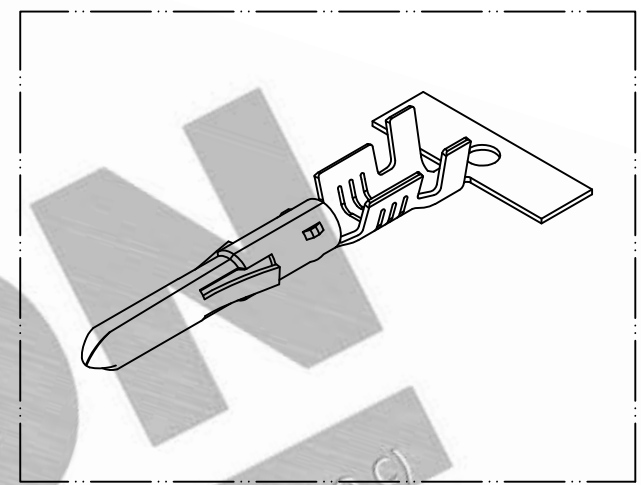
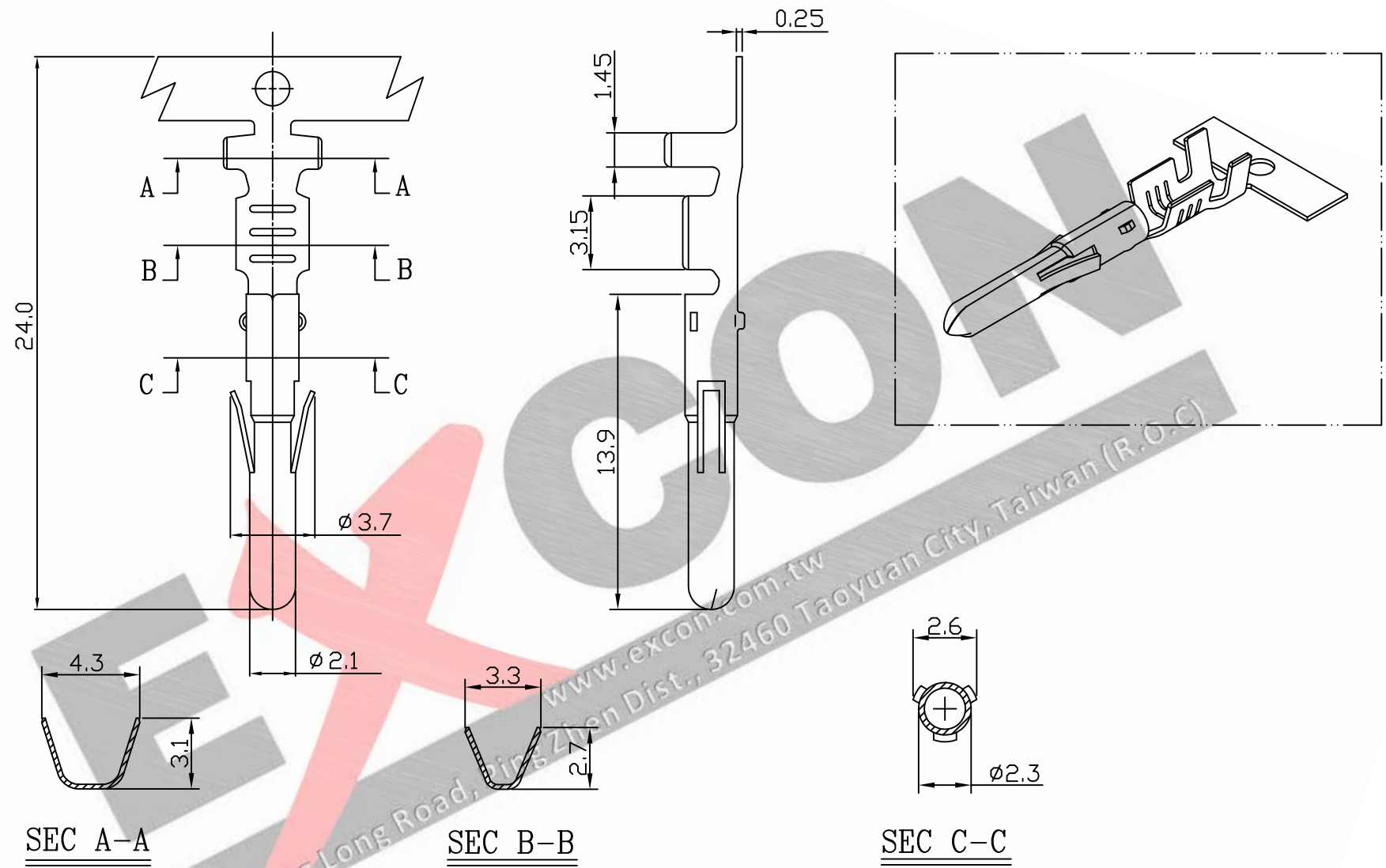

- NOTE:
1. Terminal Material: Phosphor
 2. Plated: Tin-plated 50u"min.
 3. Applicable wires: AWG#18-#24
 4. Insulation O.D.: 1.3-2.5mm
 5. Q'ty/reel: 7,000pcs

| | | | | | | |
|-------|-----------|-------|------------------------|---------------------------------------|------|--|
| | | | | UNLESS OTHERWISE SPECIFIED TOLERANCES | | EXCON EXCON TECHNOLOGY COMPANY |
| | | | | 3 PLACE ±0.5 ±0.10 | | |
| | | | | 2 PLACE ±1.5 ±0.25 | | PART.NO |
| | | | | 1 PLACE ±2.0 ±0.50 | | |
| REV. | REVISIONI | | | DIS | DATE | DWG NO: |
| SCALE | REV. | PAGE: | UNIT | mm | | |
| 4/1 | A | 1 | THIRD ANGLE PROJECTION | | | C5082TC |
| | | | | | | PART.NO |
| | | | | | | 508200TC351 |