

PART NO. 420100TXx51
 DWG NO. C4201TX

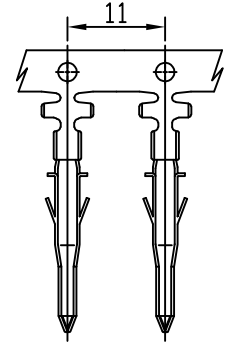
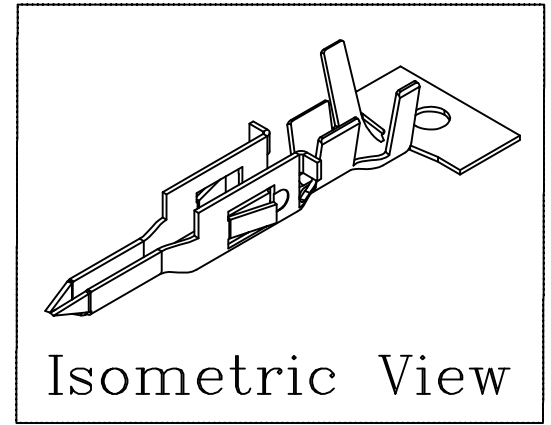
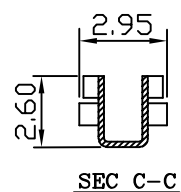
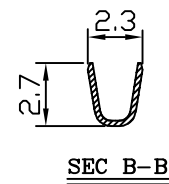
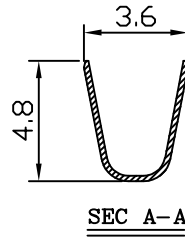
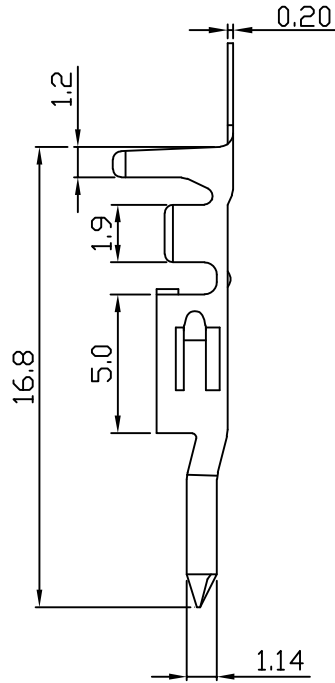
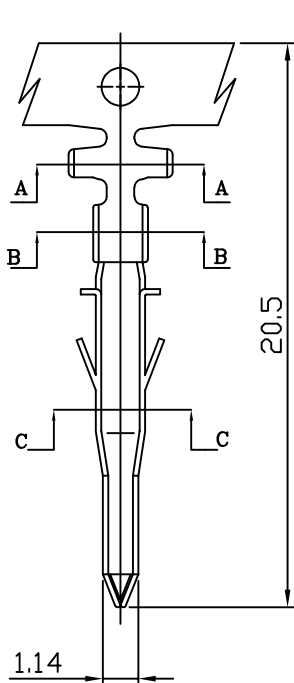

NOTE:

1. Terminal Material: Brass bronze or Phosphor bronze
2. Plated: Tin pre-plated 50u"min.
3. Current rating: 5A AC/DC
4. Voltage rating: 600V AC/DC
5. Withstand voltage: 1500V AC/minute
6. Insulation resistance: 1000MΩ min
7. Insulation O.D.: 1.7~2.8mm
8. Q'ty / reel: 4,500pcs

No.	Part No.	Wire Range	Material	Finishing
1	420100TX051	AWG#16~#20	Brass	Tin pre-plated
2	420100TX351	AWG#16~#20	Phosphor	Tin pre-plated

C		DWG RELEASE		Christy	1/7	UNLESS OTHERWISE SPECIFIED TOLERANCES		 EXCON TECHNOLOGY COMPANY
REV.	REVISION			DIS	DATE	3 PLACE ±0.5 ±0.10	2 PLACE ±1.5 ±0.25	
SCALE	REV.	PAGE:	UNIT	mm		DWG NO:	PART.NO	1 PLACE ±2.0 ±0.50 ANGLE DIM
4/1	D	1/1	THIRD ANGLE PROJECTION			C4201TX	420100TXx51	