

PART NO.
420100TPxxx

DWG NO.
C4201TP

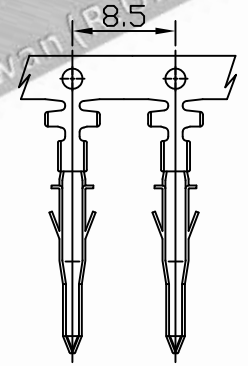
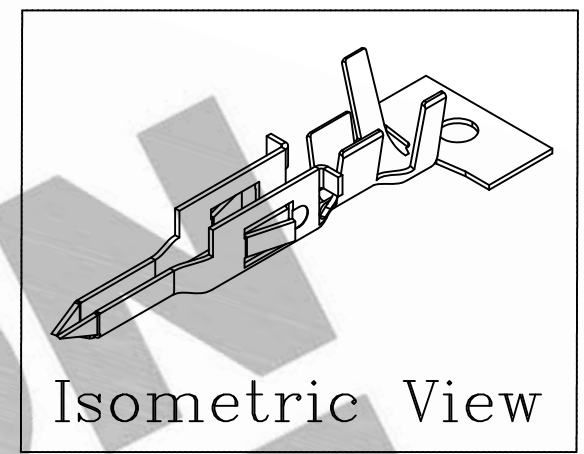
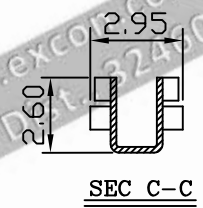
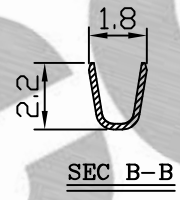
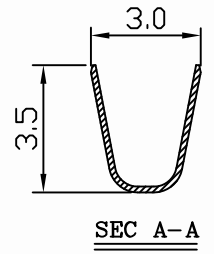
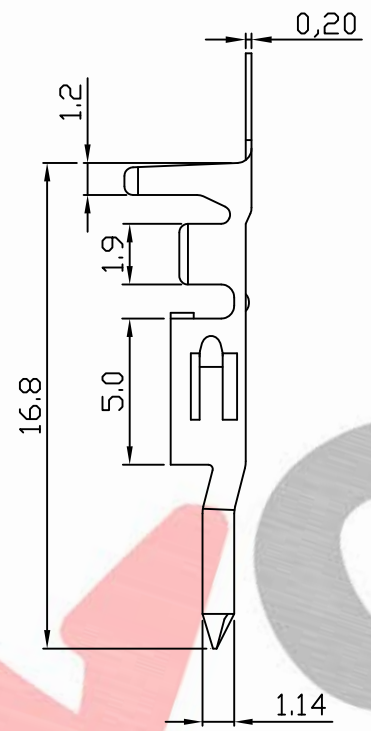
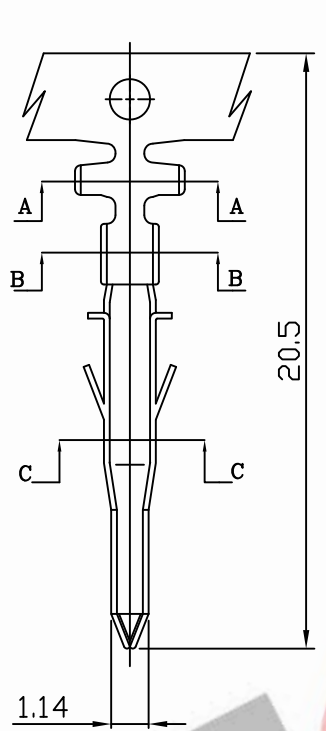

NOTE:

1. Terminal Material: Brass bronze or Phosphor bronze
2. Plated: Tin pre-plated 50u"min.
3. Current rating: 5A AC/DC
4. Voltage rating: 600V AC/DC
5. Withstand voltage: 1500V AC/minute
6. Insulation resistance: 1000MΩ min
7. Insulation O.D.: 0.9~1.8mm
8. Q'ty / reel: 7,000pcs

Dimensional & Ordering Information:

No.	Part No.	Wire Range	Material	Finishing
1	420100TP051	AWG#22~#28	Brass	Tin pre-plated
2	420100TP351	AWG#22~#28	Phosphor	Tin pre-plated

REV.	REVISIONI			DIS	DATE	UNLESS OTHERWISE SPECIFIED TOLERANCES 3 PLACE ±0.5 ±0.10 2 PLACE ±1.5 ±0.25 1 PLACE ±2.0 ±0.50 ANGLE DIM
SCALE	REV.	PAGE:	UNIT	MM	DWG NO:	
4/1	B	1/1	THIRD ANGLE PROJECTION	⊕	C4201TP	PART.NO

EXCON
EXCON TECHNOLOGY COMPANY

PART.NO
420100TPxxx

