

PART NO. 420100TAx51
 DWG NO. C4201TA

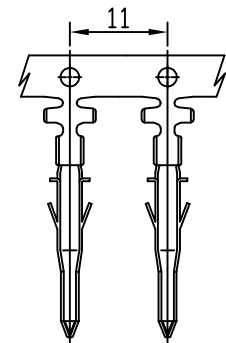
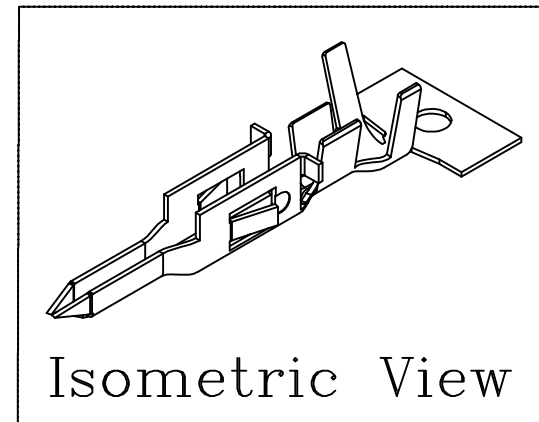
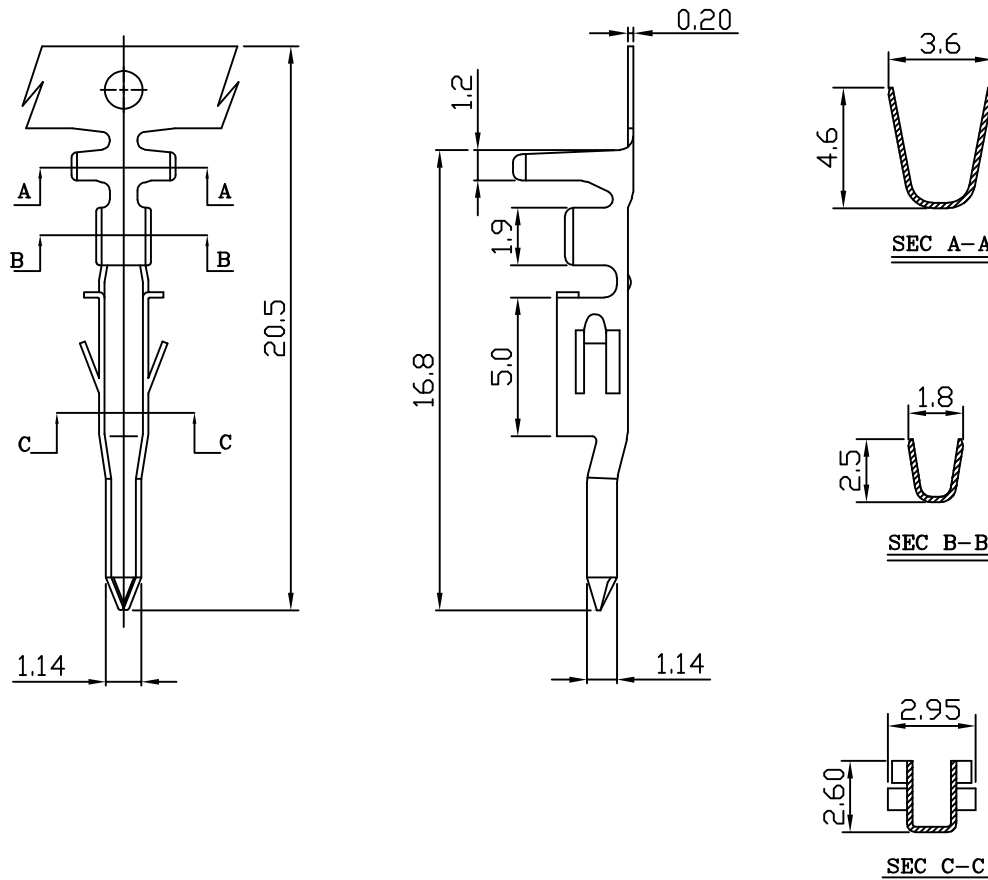

NOTE:

1. Terminal Material: Brass bronze or Phosphor bronze
2. Plated: Tin pre-plated 50u"min.
3. Current rating: 5A AC/DC
4. Voltage rating: 600V AC/DC
5. Withstand voltage: 1500V AC/minute
6. Insulation resistance: 1000MΩ min
7. Insulation O.D.: 1.1~2.1mm
8. Q'ty / reel: 4,000pcs

Dimensional & Ordering Information:

No.	Part No.	Wire Range	Material	Finishing
1	420100TA051	AWG#24~#18	Brass	Tin pre-plated
2	420100TA351	AWG#24~#18	Phosphor	Tin pre-plated

C		DWG RELEASE		Christy	12/24 2015	UNLESS OTHERWISE SPECIFIED TOLERANCES 3 PLACE ±0.5 ±0.10 2 PLACE ±1.5 ±0.25 1 PLACE ±2.0 ±0.50 ANGLE DIM	 EXCON TECHNOLOGY COMPANY
B		NOTE: 修改 第 2 项 Tin-Plated → Tin pre-Plated 新增 第 3、4、5、6 项 及 版号 TO.2		Christy	5/26 2015		
REV.	REVISION				DIS	DATE	
SCALE	REV.	PAGE:	UNIT mm		DWG NO:		PART.NO
4/1	C	1/1	THIRD ANGLE PROJECTION		C4201TA		420100TAx51