

10

9

8

7

6

5

4

3

2

1

PART NO. 255100TC351
 DWG NO. C2551TC

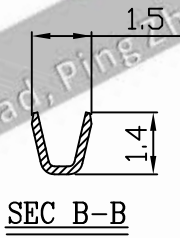
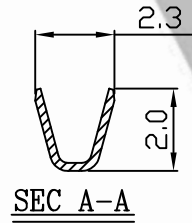
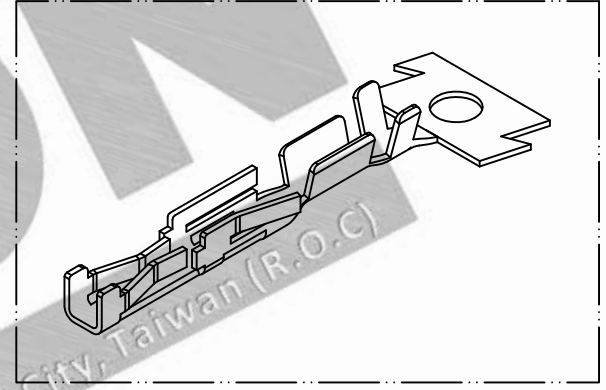
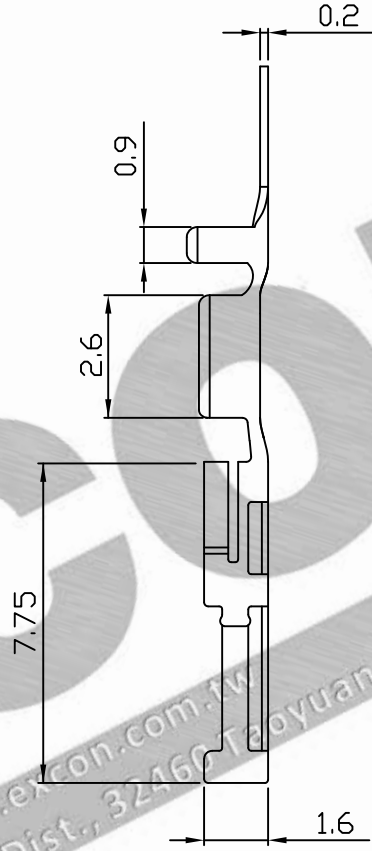
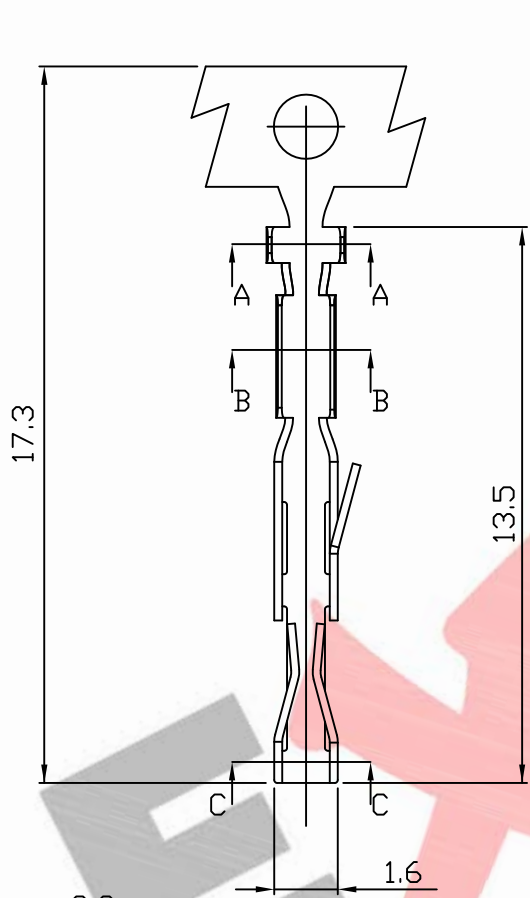

Part No.	Wire Range	Material	Finish
255100TC351	AWG#28~#22	phosphor	Tin pre-plated
255100TC501	AWG#28~#22	phosphor	Gold flash

NOTE:

1. Terminal Material: phosphor bronze
2. Plated: Tin-plated 50u"min.
3. Applicable wires: AWG#28~#22
4. Insulation O.D.: 0.9~1.6mm
5. Q'ty / reel: 20,000 PCS

REV.	REVISIONI	DIS	DATE
4/1	A	1	

SCALE: REV. PAGE: UNIT mm

THIRD ANGLE PROJECTION

UNLESS OTHERWISE SPECIFIED TOLERANCES
 3 PLACE ±0.5 ±0.10
 2 PLACE ±1.5 ±0.35
 1 PLACE ±2.0 ±0.50
 ANGLE DIM

EXCON
 EXCON TECHNOLOGY COMPANY

PART.NO: 255100TC351

10

9

8

7

6

5

4

3

2

1