

10 9 8 7 6 5 4 3 2 1

PART NO. 255000TC351
 DWG NO. C2550TC

F
 D
 C
 B
 A

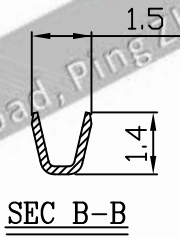
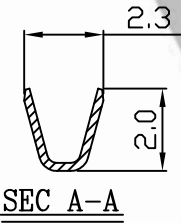
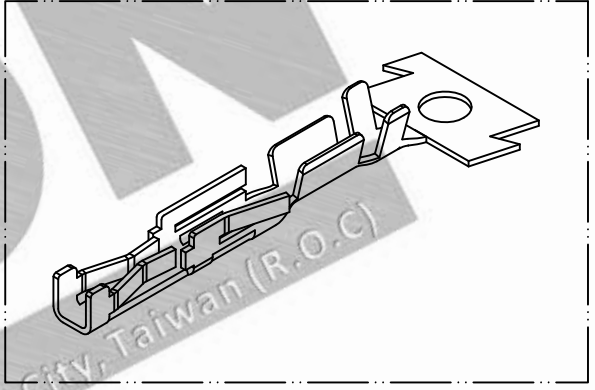
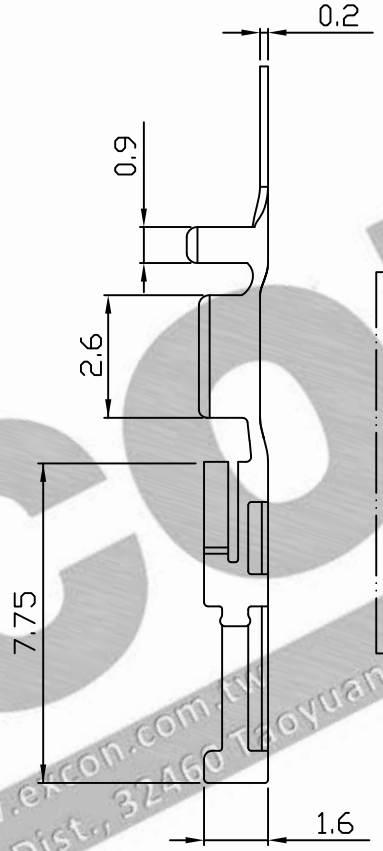
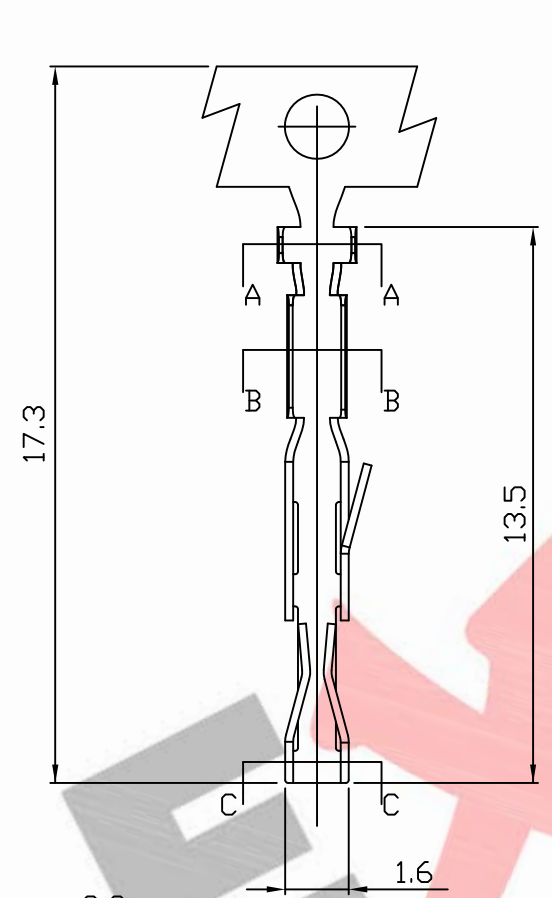

- NOTE:
1. Terminal Material: phosphor bronze
 2. Plated: Tin-plated 50u"min.
 3. Applicable wires: AWG#28~#22
 4. Insulation O.D.: 0.9~1.6mm
 5. Q'ty / reel: 20,000 PCS

Part No.	Wire Range	Material	Finish
255000TC351	AWG#28~#22	phosphor	Tin pre-plated
255000TC501	AWG#28~#22	phosphor	Gold flash

REV.	REVISION	DIS	DATE
4/1	A	1	

SCALE: UNIT: mm

THIRD ANGLE PROJECTION

UNLESS OTHERWISE SPECIFIED TOLERANCES
 3 PLACE ±0.5 ±0.10
 2 PLACE ±1.5 ±0.35
 1 PLACE ±2.0 ±0.50
 ANGLE DIM

DWG NO: C2550TC

EXCON
 EXCON TECHNOLOGY COMPANY

PART.NO: 255000TC351

10 9 8 7 6 5 4 3 2 1