

PART NO. 254800TC351  
 DWG NO. C2548TC

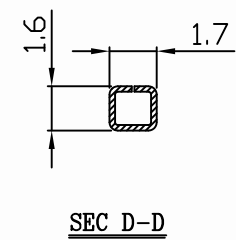
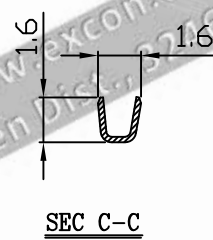
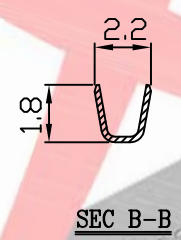
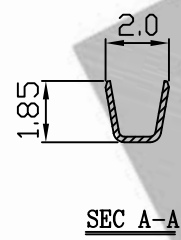
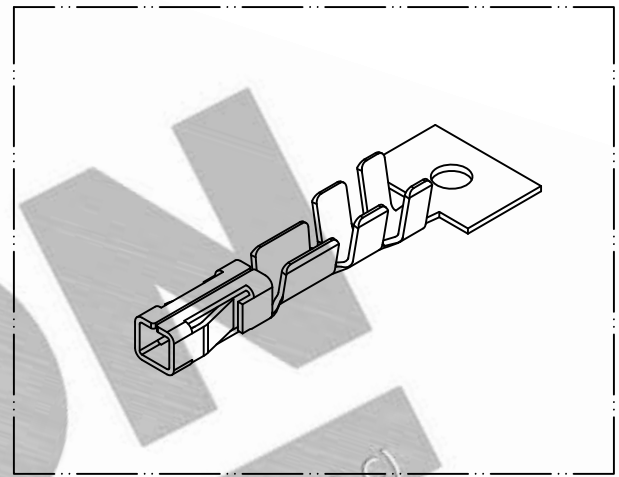
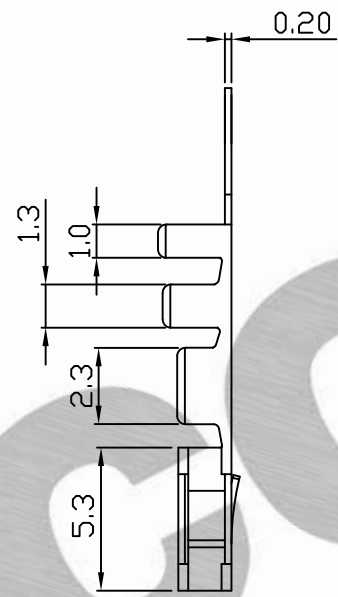
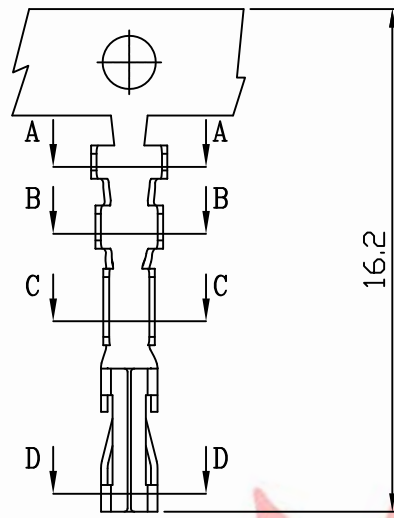

NOTE:

1. Terminal Material: phosphor bronze
2. Plated: Tin-plated 50u"min.
3. Applicable wires: AWG#26~#22
4. Insulation O.D.: 0.9~1.55mm
5. Q'ty / reel: 20,000 PCS

Part No.	Wire Range	Material	Finish
254800TC351	AWG#26~#22	phosphor	Tin pre-plated
254800TC501	AWG#26~#22	phosphor	Gold flash

REV.	REVISION	DIS	DATE
SCALE	REV.	PAGE:	UNIT
6/1	A	1	mm

UNLESS OTHERWISE SPECIFIED TOLERANCES  
 3 PLACE ±0.5 ±0.10  
 2 PLACE ±1.5 ±0.25  
 1 PLACE ±2.0 ±0.50  
 ANGLE DIM

DWG NO: C2548TC

**EXCON**  
 EXCON TECHNOLOGY COMPANY

PART.NO: 254800TC351

