

10 9 8 7 6 5 4 3 2 1

PART NO. 254500TA301
 DWG NO. C2545TA

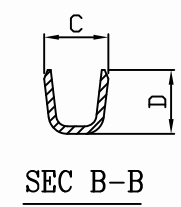
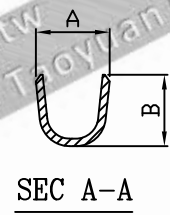
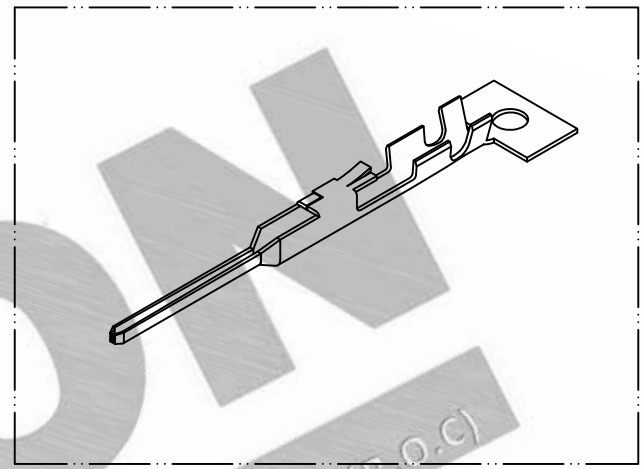
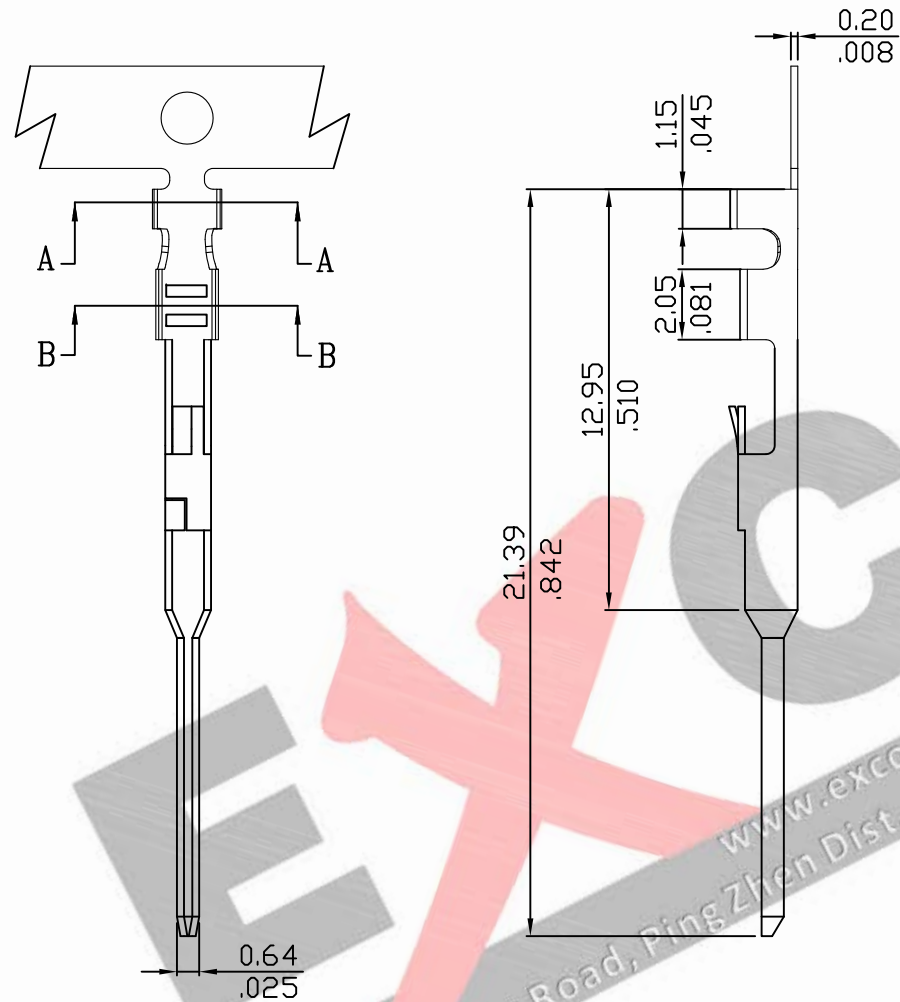

NOTE:

1. Terminal Material: phosphor bronze
2. Plated: Tin plated 50u"min.
3. Applicable wires: AWG#28~#24
4. Insulation O.D.: 1.2~1.7mm
5. Q'ty / reel: 15,000 PCS

				UNLESS OTHERWISE SPECIFIED TOLERANCES		EXCON EXCON TECHNOLOGY COMPANY
				3 PLACE ±0.5 ±0.10		
				2 PLACE ±1.5 ±0.25		PART.NO
				1 PLACE ±2.0 ±0.50		
REV.	REVISIONI			DIS	DATE	DWG NO: C2545TA
SCALE	REV.	PAGE:	UNIT	mm		
3/1	A	1	THIRD ANGLE PROJECTION			PART.NO 254500TA301

F
E
D
C
B
A

F
E
D
C
B
A

10 9 8 7 6 5 4 3 2 1