

10 9 8 7 6 5 4 3 2 1

PART NO. 251600TC351  
 DWG NO. C2516TC

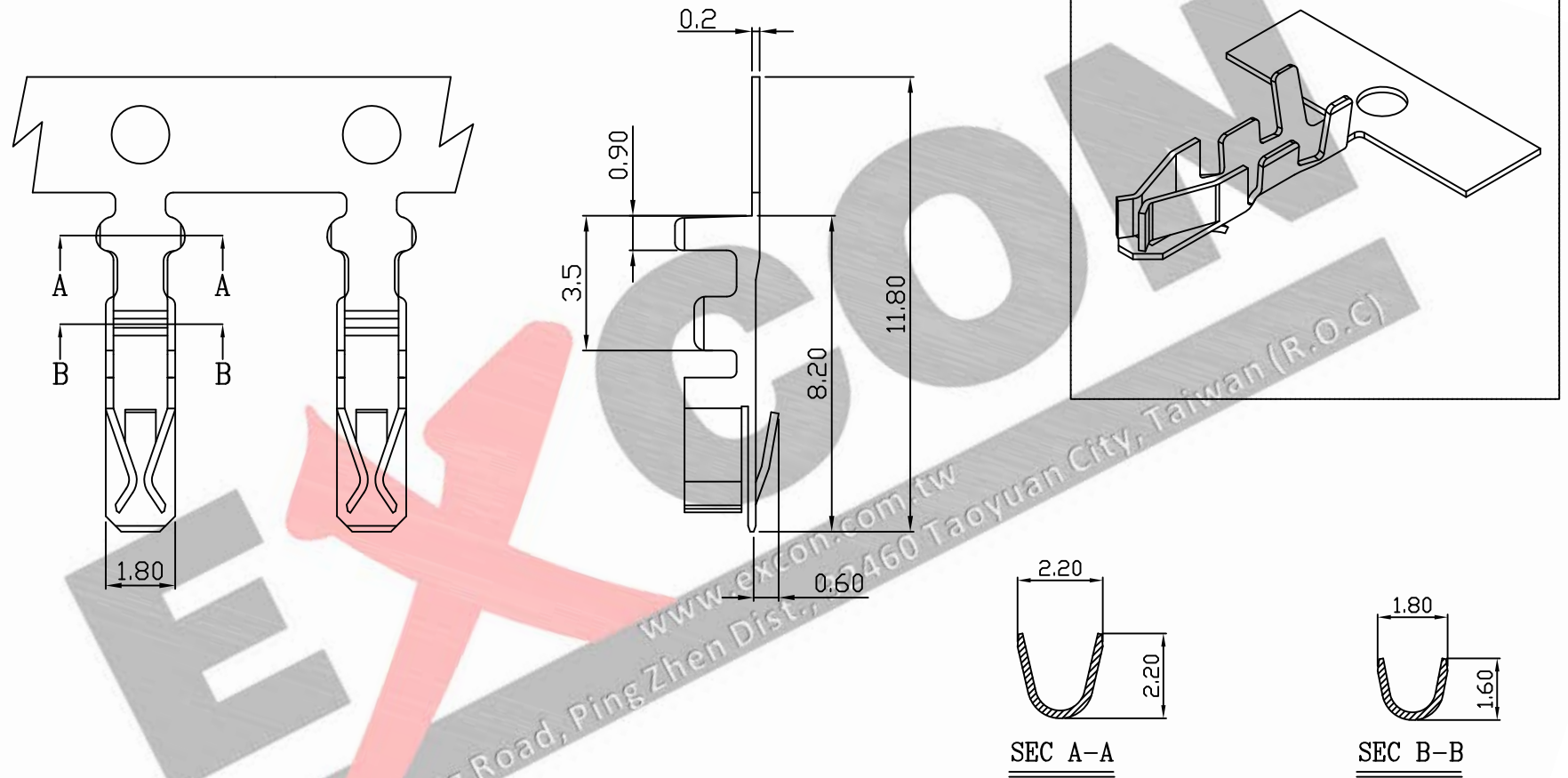

**NOTE:**

1. Terminal Material:  
Phosphor bronze
2. Plated: Tin-plated 50u"min.
3. Applicable wires: AWG#28-#22
4. Insulation O.D.: 1.0-1.5mm
5. Q'ty / reel: 10,000 pcs

				UNLESS OTHERWISE SPECIFIED TOLERANCES		<b>EXCON</b> EXCON TECHNOLOGY COMPANY
				3 PLACE ±0.5 ±0.10		
				2 PLACE ±1.5 ±0.35		
				1 PLACE ±2.0 ±0.50		
REV.	REVISION			DIS	DATE	ANGLE DIM
SCALE	REV.	PAGE:	UNIT	mm		DWG NO:
5/1	A	1/1	THIRD ANGLE PROJECTION			C2516TC
					PART.NO	
					251600TC351	

10 9 8 7 6 5 4 3 2 1