

PART NO. 251400TC051  
 DWG NO. C2514TC

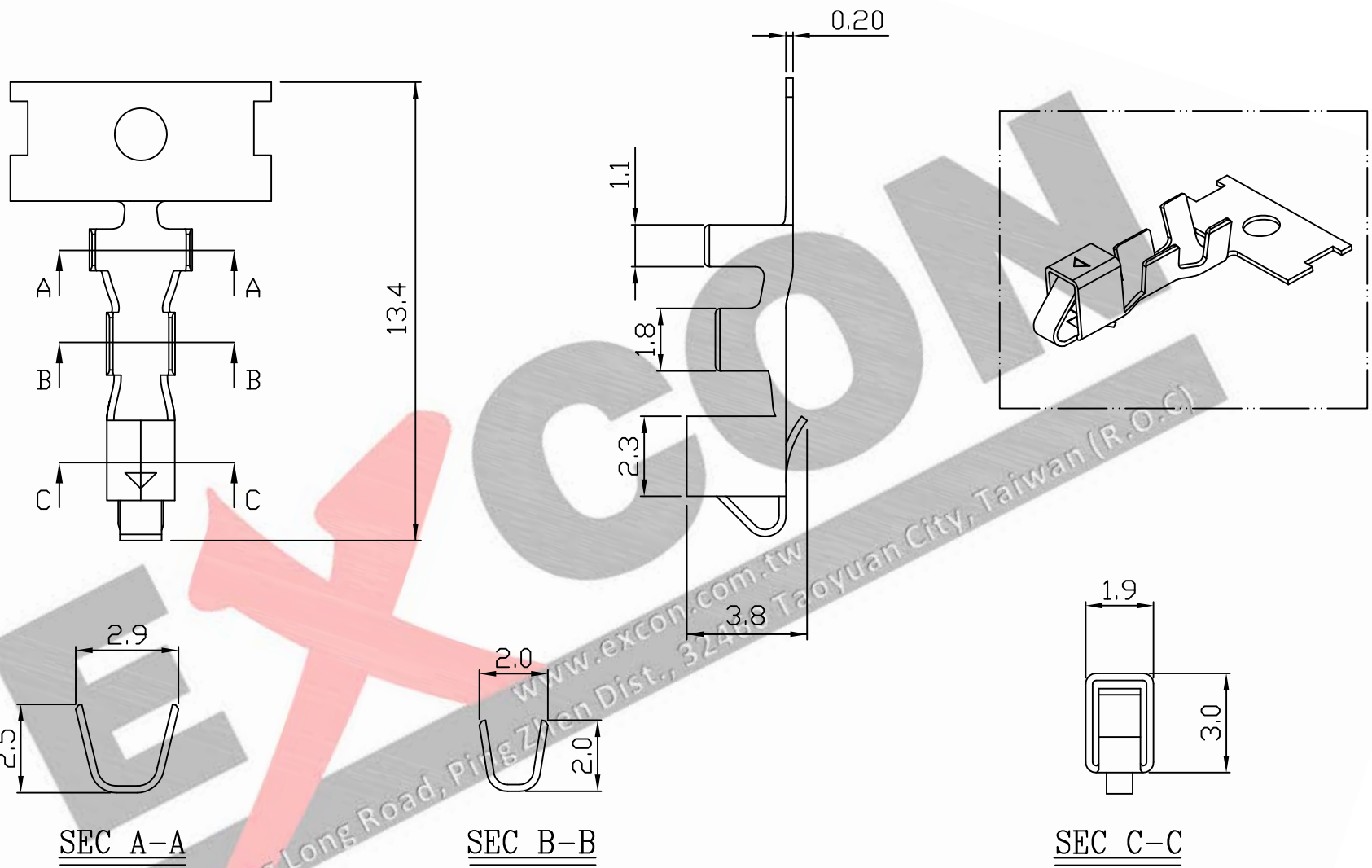

NOTE 1 :

1. Terminal Material: Brass
2. Plated: Ni 25u"min Tin-plated 50u"min.
3. Applicable wires: #28~#22
4. Q'ty / reel: 7,000 pcs

				UNLESS OTHERWISE SPECIFIED TOLERANCES		 <b>EXCON TECHNOLOGY COMPANY</b>
				3 PLACE ±0.5 ±0.10		
				2 PLACE ±1.5 ±0.25		
				1 PLACE ±2.0 ±0.50		
REV.	REVISIONI			DIS	DATE	ANGLE DIM
SCALE	REV.	PAGE:	UNIT	mm		DWG NO:
4/1	A	1	THIRD ANGLE PROJECTION			C2514TC
					PART.NO	
					251400TC051	