

PART NO. 251200TCxxx
 DWG NO. C2512TC

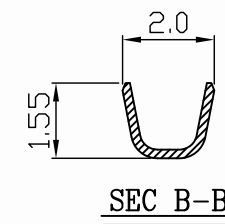
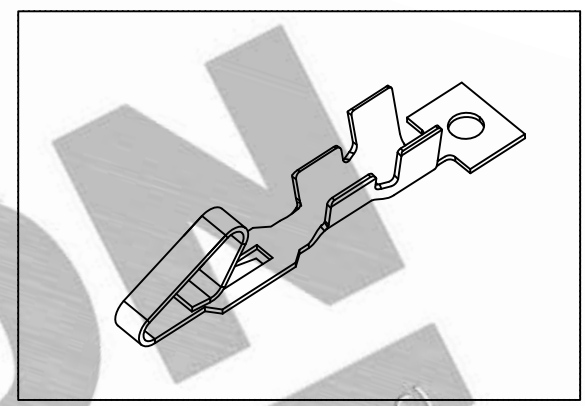
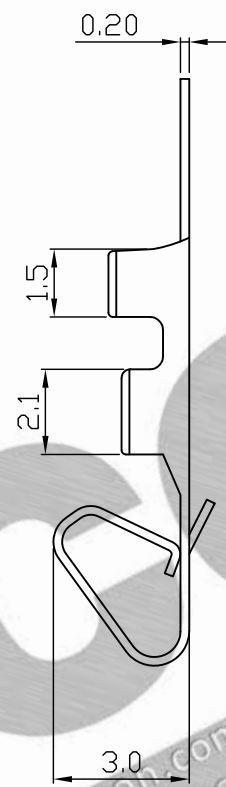
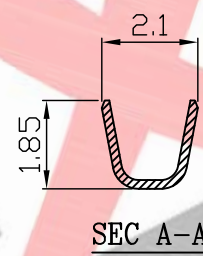
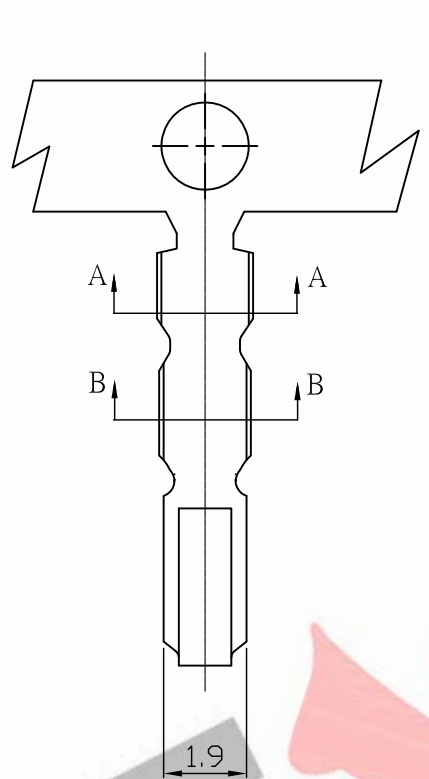

- NOTE:
1. Terminal Material:
Phosphor, Brass bronze
 2. Plated: Tin-plated 50u"min.
 3. Applicable wires: AWG#28-#22
 4. Insulation O.D.: 1.2-1.7mm
 5. Q'ty / reel: 10,000 pcs

Part No.	Wire Range	Insulation O.D.	Material	Finish	Q'ty/reel
251200TC351	AWG#28~#22	1.2-1.7mm	Phosphor	Tin pre-plated	10,000pcs
251200TC051	AWG#28~#22	1.2-1.7mm	Brass	Tin pre-plated	10,000pcs

UNLESS OTHERWISE SPECIFIED TOLERANCES
 3 PLACE ±0.5 ±0.10
 2 PLACE ±1.5 ±0.25
 1 PLACE ±2.0 ±0.50
 ANGLE DIM



REV.	REVISION	DIS	DATE	SCALE	REV.	PAGE:	UNIT	mm	DWG NO:	PART.NO
6/1	A	1					THIRD ANGLE PROJECTION		C2512TC	251200TCxxx