

10 9 8 7 6 5 4 3 2 1

PART NO. 251000TCxxx
 DWG NO. C2510TC

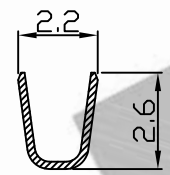

SEC A-A

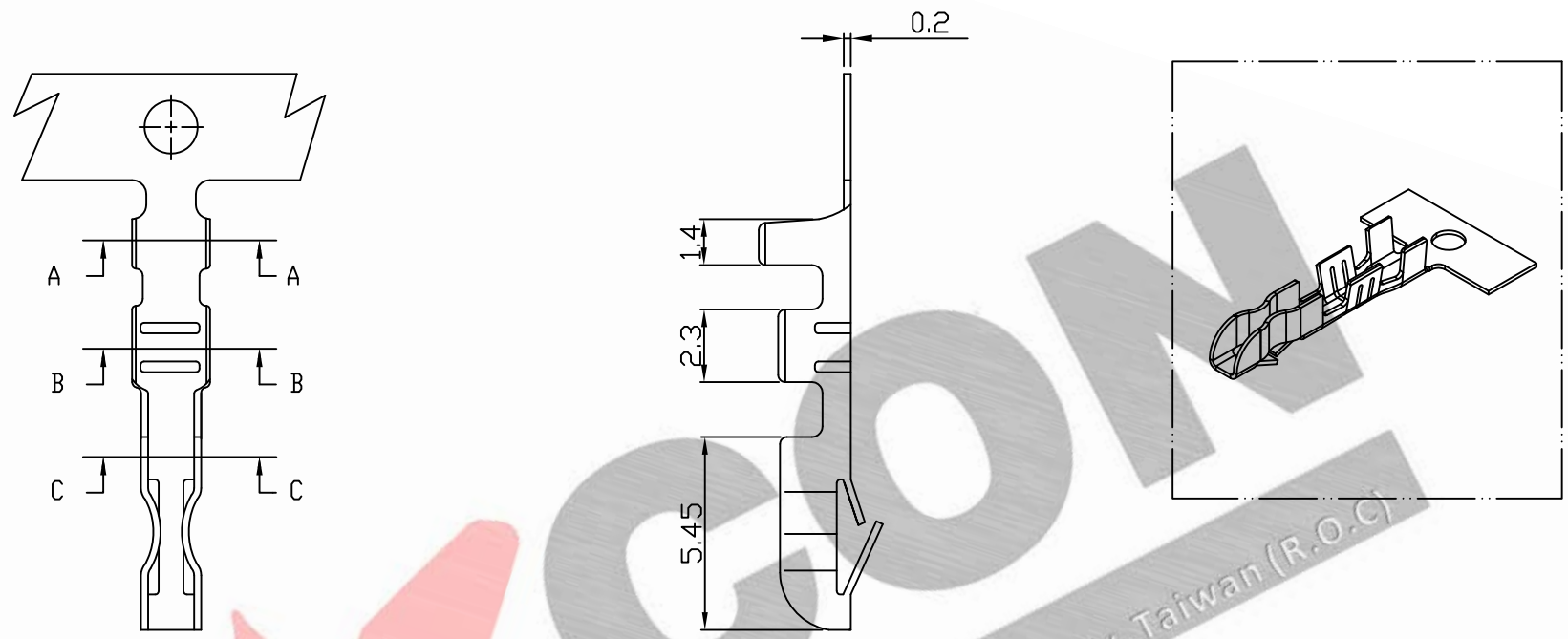
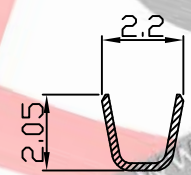

SEC B-B

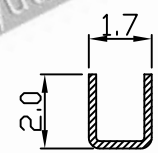

SEC C-C

NOTE:

1. Terminal Material: See table
2. Plated: Ni 25u"min Tin-plated 50u"min.
3. Plated: Tin-plated 50u"min.
4. Applicable wires: #28~#22
5. Q'ty / reel: 10,000 pcs

Part No.	Wire Range	Material	Finishing	Q'ty/reel
251000TC351	AWG#28~#22	Phosphor	Tin pre-plated	10,000pcs
251000TC051	AWG#28~#22	Brass	Tin pre-plated	10,000pcs

				UNLESS OTHERWISE SPECIFIED TOLERANCES		 EXCON TECHNOLOGY COMPANY
				3 PLACE ±0.5 ±0.10		
				2 PLACE ±1.5 ±0.25		
				1 PLACE ±2.0 ±0.50		
				ANGLE DIM		
REV.	REVISIONI			DIS	DATE	
SCALE	REV.	PAGE:	UNIT	mm		DWG NO:
4/1	A	1	THIRD ANGLE PROJECTION			C2510TC
					PART.NO	251000TCxxx

10 9 8 7 6 5 4 3 2 1