

PART NO. 250400TC351
 DWG NO. C2504TC

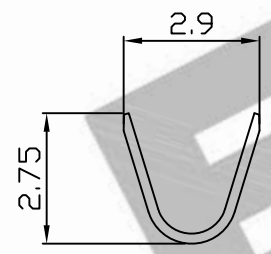

SEC A-A

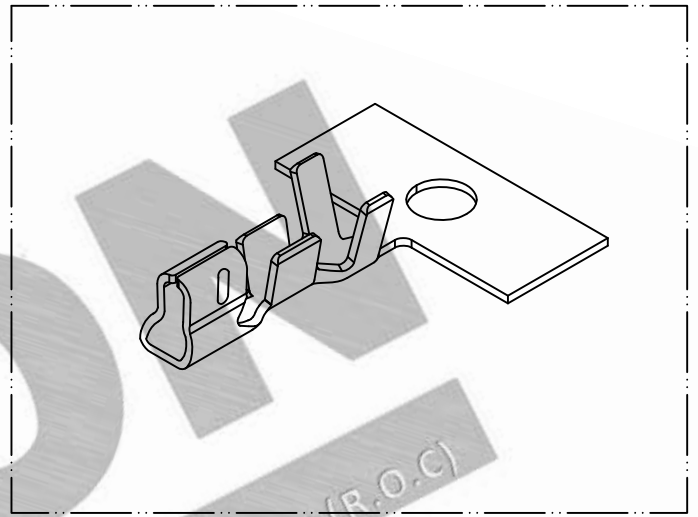
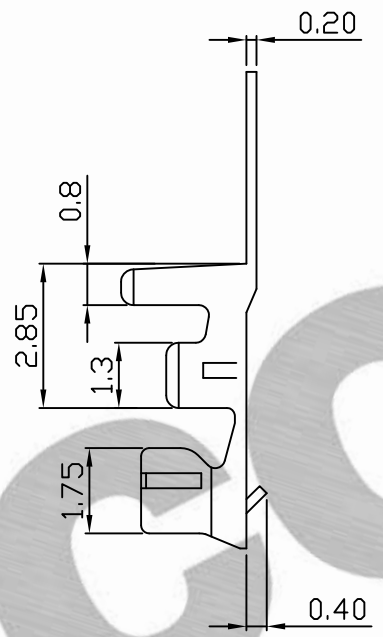
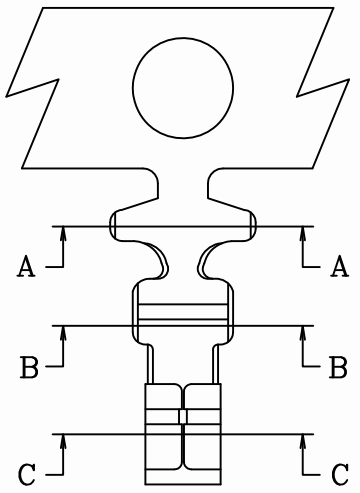
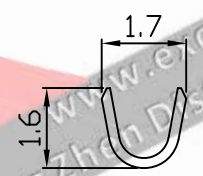

SEC B-B

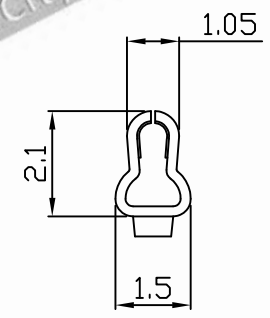

SEC C-C

NOTE:

1. Terminal Material: phosphor bronze.
2. Plated: Tin-plated 50u"min.
3. Applicable wires: AWG#28-#22
4. Insulation O.D.: 1.2-1.8mm
5. Q'ty / reel: 10,000 pcs

				UNLESS OTHERWISE SPECIFIED TOLERANCES		EXCON EXCON TECHNOLOGY COMPANY
				3 PLACE ±0.5 ±0.10 2 PLACE ±1.5 ±0.25 1 PLACE ±2.0 ±0.50		
REV.	REVISION			DIS	DATE	PART.NO
SCALE	REV.	PAGE:	UNIT	mm		
8/1	A	1	THIRD ANGLE PROJECTION			C2504TC
						250400TC351