

PART NO. 250200TCXXX
 DWG NO. C2502TC

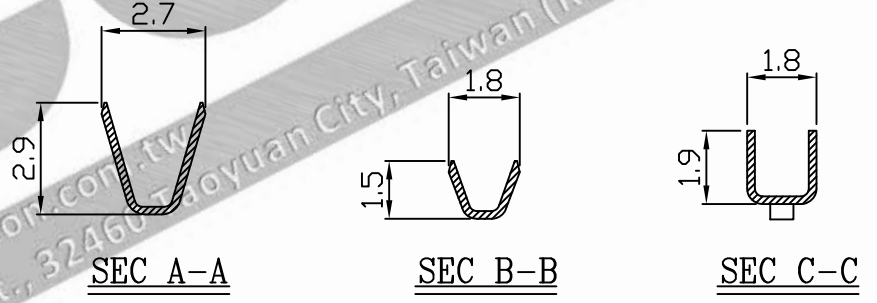
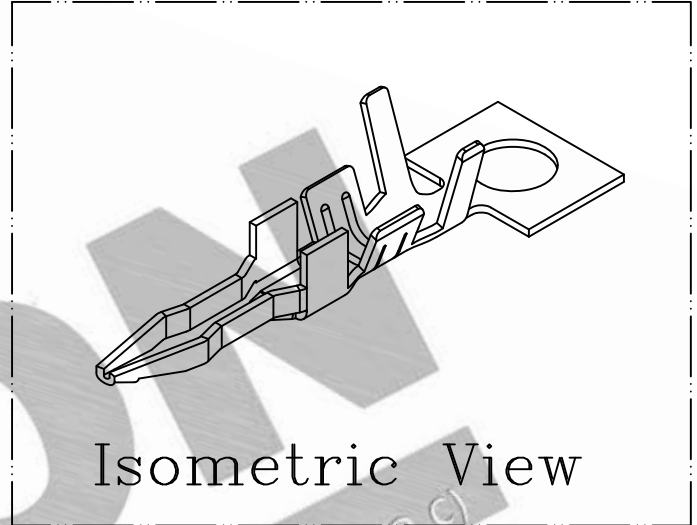
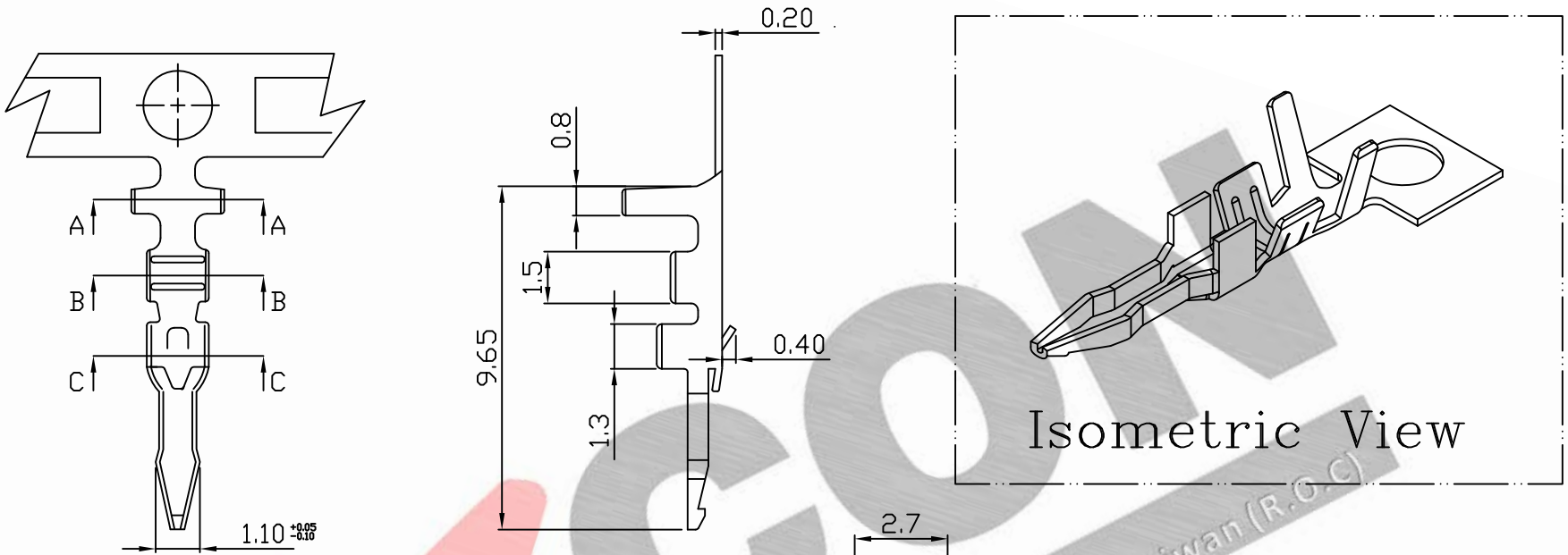

NOTE:

1. Terminal Material: Brass bronze or Phosphor bronze
2. Plated: Tin pre-plated or Tin-plated 50u"min.
3. Current rating: 3A AC/DC
4. Voltage rating: 250V AC/DC
5. Withstand voltage: 800V AC/minute
6. Insulation resistance: 1000MΩ min
7. Applicable wires: AWG#28-#22
8. Insulation O.D.: 1.2-1.9mm
9. Q'ty / reel: 10,000pcs

Ordering Information and Dimensions:

Part No.	Material	Finishing
250200TC001	Brass	Tin plated
250200TC051		Tin pre-plated
250200TC301	Phosphor	Tin plated
250200TC351		Tin pre-plated

REV.	REVISION		DIS	DATE
SCALE	REV.	PAGE:	UNIT mm	
5/1	D	1/1	THIRD ANGLE PROJECTION	

UNLESS OTHERWISE SPECIFIED TOLERANCES
 3 PLACE ±0.5 ±0.10
 2 PLACE ±1.5 ±0.25
 1 PLACE ±2.0 ±0.50
 ANGLE DIM



DWG NO:	PART.NO
C2502TC	250200TCXXX

D 1.NOTE:
 新增 第3、4、5、6項
 2.新增鍍厚 T0.20

christy 5/12 2015