

PART NO. 200700TC351
 DWG NO. C2007TC

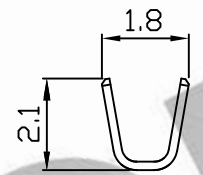

SEC A-A

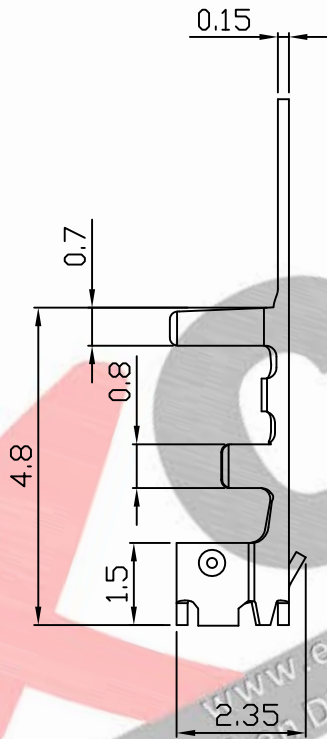
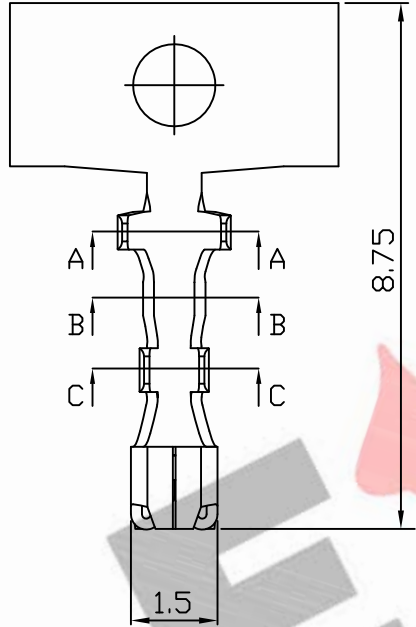
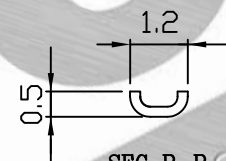

SEC B-B

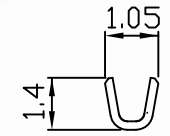

SEC C-C

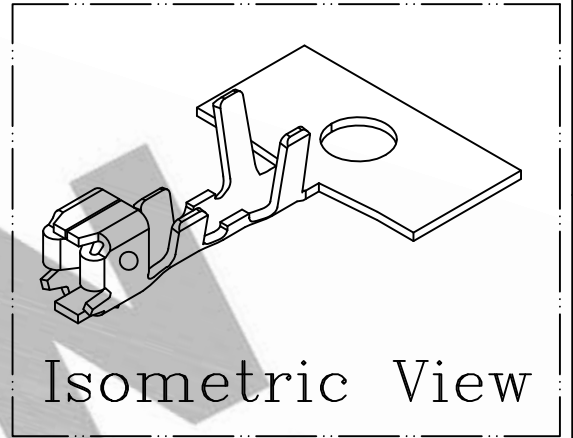

NOTE:

1. Terminal Material: Phosphor bronze
- ⚠ 2. Plated: Ni 25u"min Tin pre-plated 50u"min.
- ⚠ 3. Current rating: 2A AC/DC
- ⚠ 4. Voltage rating: 250V AC/DC
- ⚠ 5. Withstand voltage: 800V AC/minute
- ⚠ 6. Insulation resistance: 1000MΩ min
7. Applicable wires: AWG#28-#24
8. Insulation O.D.: 0.9~1.5mm
9. Q'ty / reel: 10,000pcs

REV.	REVISIONI		DIS	DATE
B	NOTE: 修改 第2項 Tin-Plated → Tin pre-Plated 新增 第3、4、5、6項		ohriaty	5/28 2015
SCALE	REV.	PAGE:	UNIT mm	
4/1	B	1/1	THIRD ANGLE PROJECTION	

UNLESS OTHERWISE SPECIFIED TOLERANCES
 3 PLACE ±0.5 ±0.10
 2 PLACE ±1.5 ±0.25
 1 PLACE ±2.0 ±0.50
 ANGLE DIM



DWG NO:	C2007TC	PART.NO	200700TC351
---------	---------	---------	-------------