

### ■ Specification

1. Current rating: 5A AC/DC
2. Voltage rating: 600 AC/DC
3. Withstand voltage: 1500V AC/minute
4. Insulation resistance: 1000M  $\Omega$  min
5. Contact resistance: 10m  $\Omega$  max
6. Temperature range:  $-25^{\circ}\text{C}$  to  $+105^{\circ}\text{C}$
7. Applicable panel thickness: 0.8~2.0mm
8. Applicable wires: AWG#26-#16  
Insulation O.D.: 1.2-3.2mm
9. Circuits:1,2,3,4,6,8

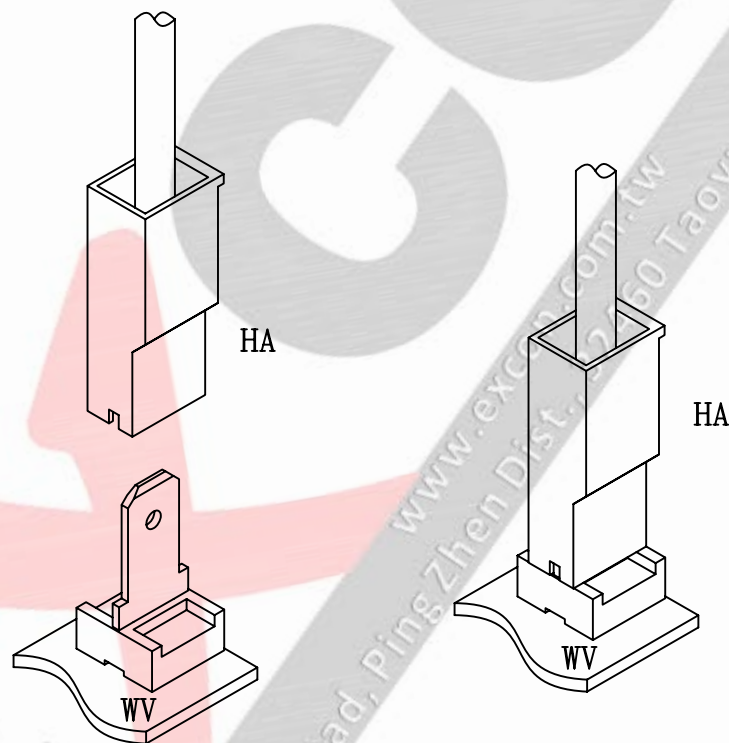

### Part Code Information:

9252-WW XX YY

① ② ③ ④

① Series Name

② Circuits Number

1

00 For Terminal

③ Product Type

HA=Housing

TC=Terminal, C type

TL=Terminal, L type

④ Material/Finishing/Color

001=Brass,Tin Plated

301=Phosphor,Tin Plated

901=Brass,UnPlated

951=Phosphor,UnPlated

051=NY66 UL94V2,Natural Color

053=NY66 UL94V2,Black Color

### Crimp Terminal

1. Part No.: 925200TCxx1,925200TYxx1
2. Part Name: 9252 Terminal
3. Material: Brass or Phosphor bronze
4. Finishing: Unplated , Tin plated  
or Tin pre-plated

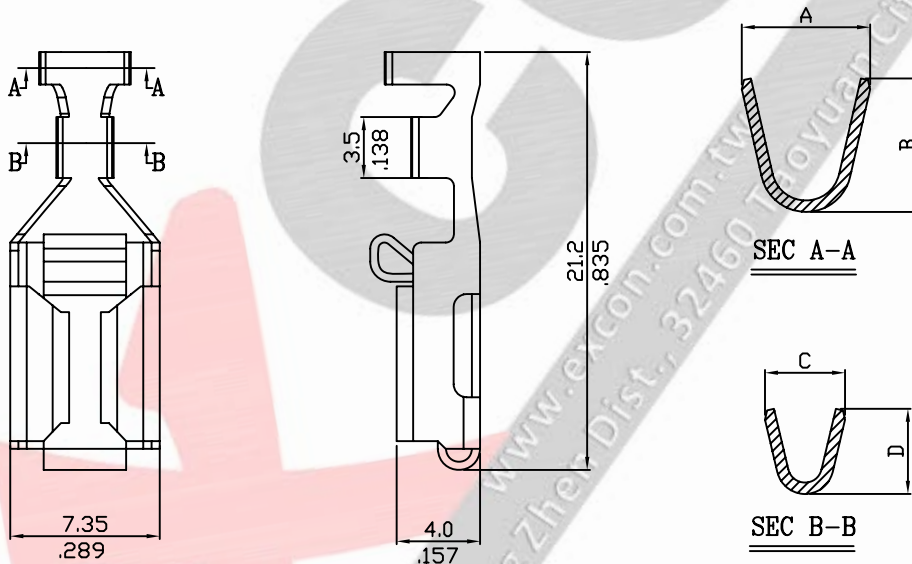
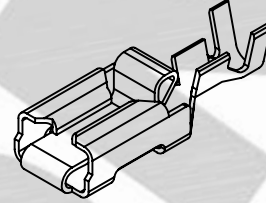

### Ordering Information and Dimension:

No.	Part No.	DIM (mm)				Wire Range	Insulation O.D.	Material
		A	B	C	D			
1	925200TLxx1	5.9	6.1	3.8	4.0	AWG#16~#14	2.7-4.0mm	Phosphor
2	925200TCxx1	4.5	4.7	2.8	3.0	AWG#20~#18	2.0-3.3mm	
3	925200TLxx1	5.9	6.1	3.8	4.0	AWG#16~#14	2.7-4.0mm	Brass
4	925200TCxx1	4.5	4.7	2.8	3.0	AWG#20~#18	2.0-3.3mm	

### Part Code Information:

9252-WW XX YY

① ② ③ ④

① Series Name

② Circuits Number

00 For Terminal

③ Product Type

TC=Terminal, C type

TL=Terminal, L type

④ Material/Finishing/Color

001=Brass,Tin Plated

051=Brass,Tin Pre-Plated

301=Phosphor,Tin Plated

351=Phosphor,Tin Pre-Plated

901=Brass,UnPlated

951=Phosphor,UnPlated

### Housing

1. Part No.: 925201HA051,925201HA053
2. Part Name: 9252 Housing
3. Material: Nylon 66 UL 94V2
4. Color: Natural,Black

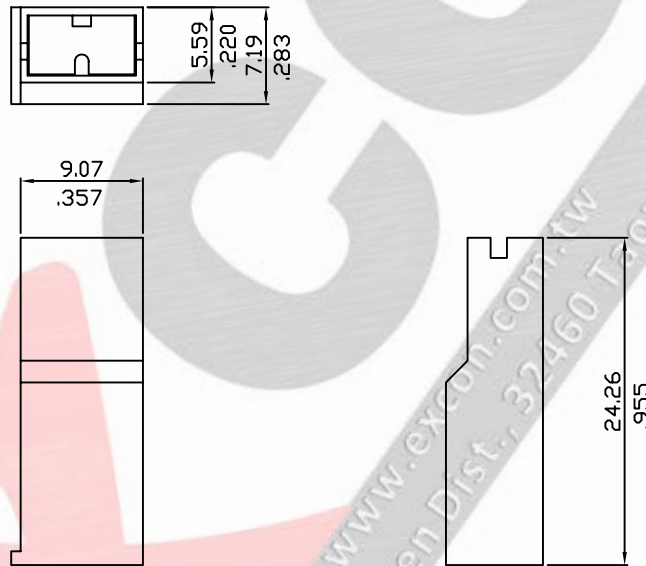
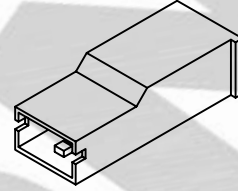

### Ordering Information and Dimensions:

#### Part Code Information:

9252-WW XX YYY

① ② ③ ④

① Series Name

② Circuits Number  
01

③ Product Type  
HA=Housing

④ Material/Finishing/Color  
051=NY 66 94V-2,Natural Color  
053=NY 66 94V-2,Black Color