

### ■ Specifications

1. Current rating: 3A AC/DC
2. Voltage rating: 250V AC/DC
3. Withstand voltage: 1000V AC/minute
4. Insulation resistance: 1000M  $\Omega$  min
5. Contact resistance: 10m  $\Omega$  max
6. Temperature range: -25°C to +105°C
7. Applicable PC board thickness: 1.0~1.6mm(.039'' to .063'')
8. Applicable wires: AWG#30-#24  
Insulation O.D.: 0.9-1.5mm
9. Circuits: 9,15,25,37 circuits available

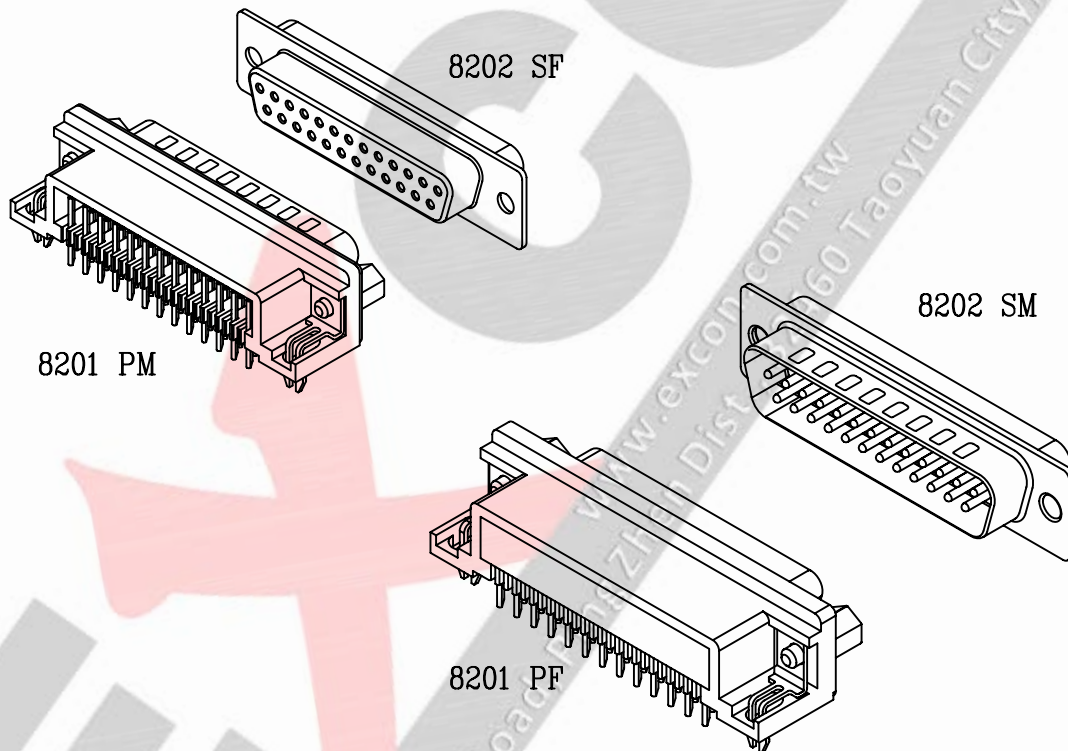

### Part Code Information:

8201-WW XX YYY

① ② ③ ④

① Series Name

② Circuits Number  
09,15,25,37

③ Product Type

PM=D\_SUB Male(Dip)

PF=D\_SUB Female(Dip)

SM=D\_SUB Male(Solder)

SF=D\_SUB Female(Solder)

④ Material/Finishing/Color

203=PBT UL 94 V0,Black Color

### D\_SUB Male

1. Part No.: 8201xxPM203
2. Part Name: D\_SUB
3. Wafer Material: PBT UL94V0  
Pin/pos Material: Brass bronze
4. Finishing: Tin-plated 50" min.

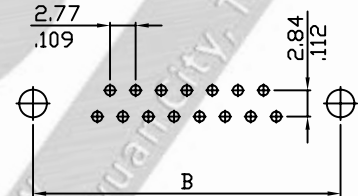
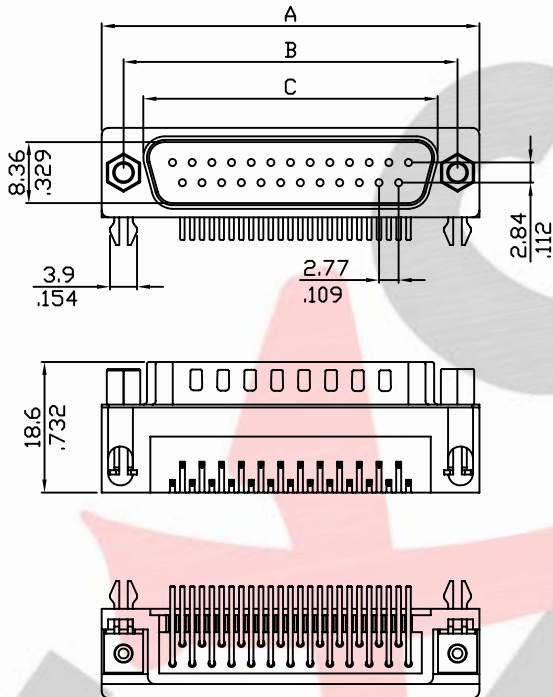
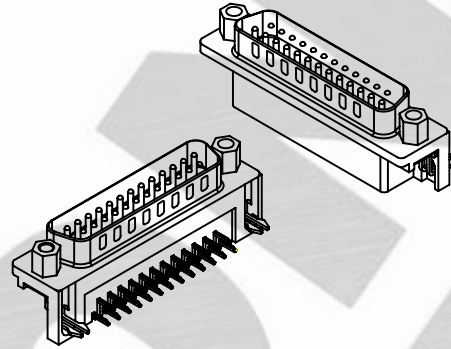

### Ordering Information and Dimensions:

Part No.	Circuits	Dim A	Dim B	Dim C
820109PM203	9	30.81(1.213)	24.99(.984)	16.92(.666)
820115PM203	15	39.14(1.541)	33.32(1.312)	25.25(.994)
820125PM203	25	53.04(2.088)	47.04(1.852)	38.96(1.534)
820137PM203	37	69.32(2.729)	63.05(2.482)	55.42(2.182)

### Part Code Information:

8201-WW XX YYY

① ② ③ ④

③ Product Type  
PM=D\_SUB Male(Dip)

④ Material/Finishing/Color  
203=PBT UL 94 V0,Black Color

① Series Name

② Circuits Number  
09,15,25,37

### D\_SUB Female

1. Part No.: 8201xxPF203
2. Part Name: D\_SUB
3. Wafer Material: PBT UL94V0  
Pin/pos Material :Brass bronze
4. Finishing: Tin-plated 50" min.

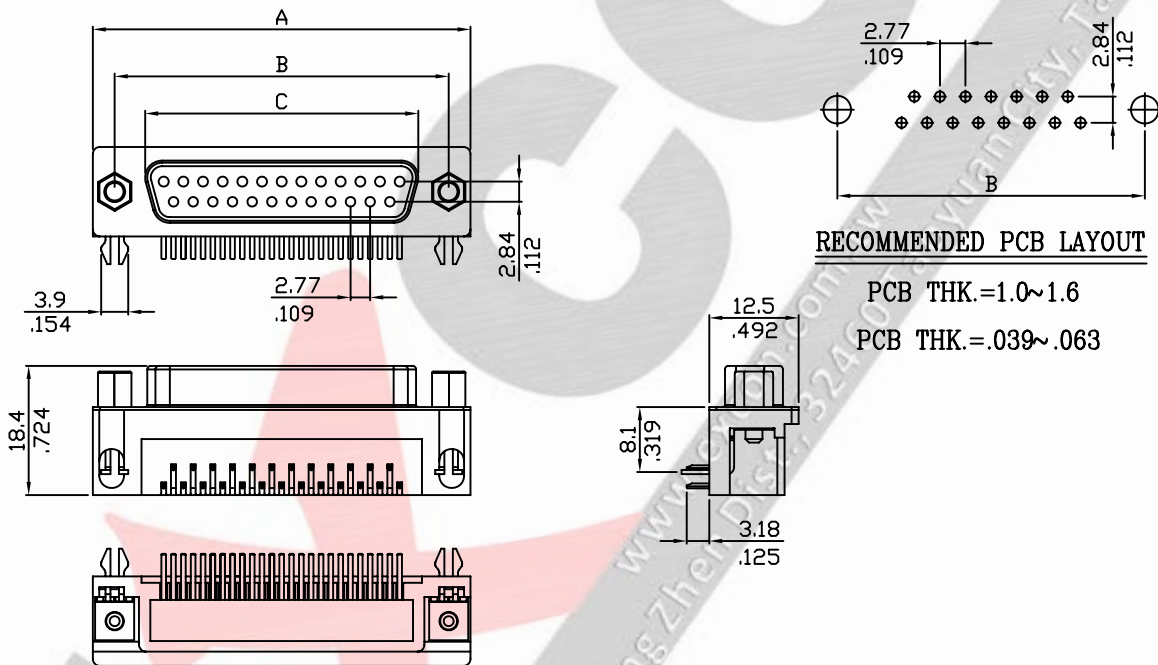
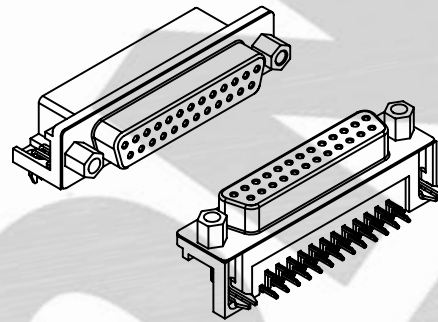

### Ordering Information and Dimensions:

Part No.	Circuits	Dim A	Dim B	Dim C
820109PF203	9	30.81(1.213)	24.99(.984)	16.30(.642)
820115PF203	15	39.14(1.541)	33.32(1.312)	24.66(.971)
820125PF203	25	53.04(2.088)	47.04(1.852)	38.38(1.511)
820137PF203	37	69.32(2.729)	63.05(2.482)	54.84(2.159)

### Part Code Information:

8201-WW XX YY

① ② ③ ④

① Series Name

② Circuits Number

09,15,25,37

③ Product Type

PF=D\_SUB Female(Dip)

④ Material/Finishing/Color

203=PBT UL 94 V0,Black Color