

■ Specifications

1. Current rating: 3A AC/DC
2. Voltage rating: 250V AC/DC
3. Withstand voltage: 1000V AC/minute
4. Insulation resistance: 1000M Ω min
5. Contact resistance: 10m Ω max
6. Temperature range: -40°C to +105°C
7. Applicable PC board thickness: 1.0~1.6mm(.039" to .063")
8. Applicable wires: AWG#28-#22
Insulation O.D.: 0.9-1.6mm
9. Circuits: 6~36 circuits available

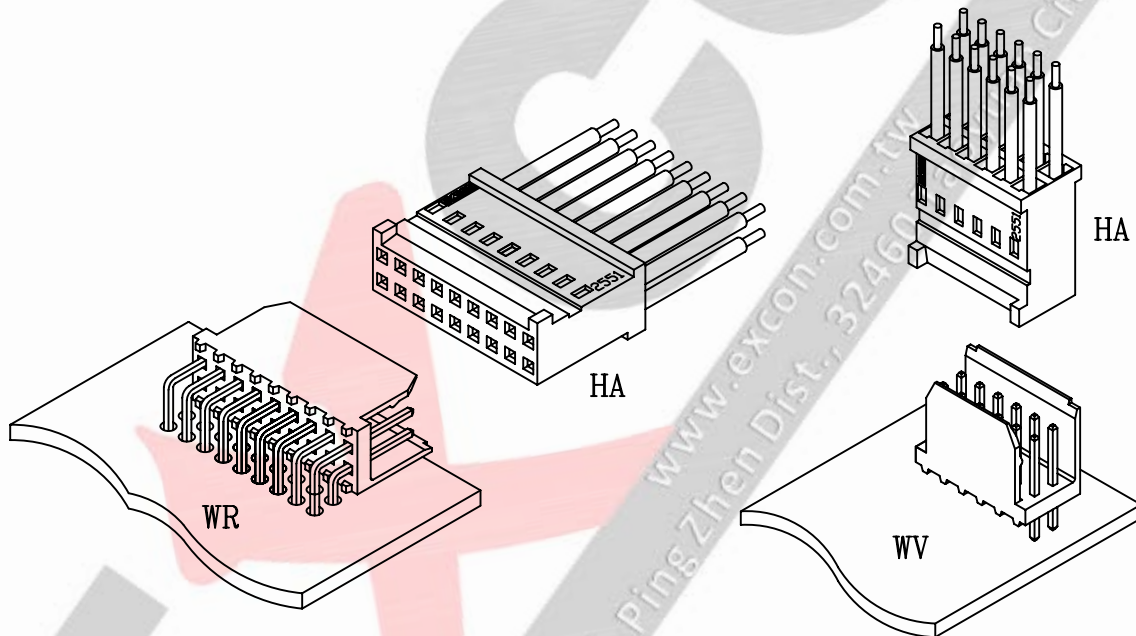

Part Code Information:

2551-WW XX YY

① ② ③ ④

① Series Name

② Circuits Number

06~36

00 For Terminal

③ Product Type

HA=Housing

WV=Wafer (Vertical Type)

WR=Wafer (Right Angle Type)

TC=Terminal

④ Material/Finishing/Color

351=Phosphor,Tin Pre-Plated

501=Phosphor,Gold flash

203=PBT UL 94V-0,Black Color

Crimp Terminal

1. Part No.: 255100TC351 , 255100TC501
2. Part Name: 2551 Terminal
3. Material: Phosphor bronze
4. Finishing: Tin pre-plated , Gold flash

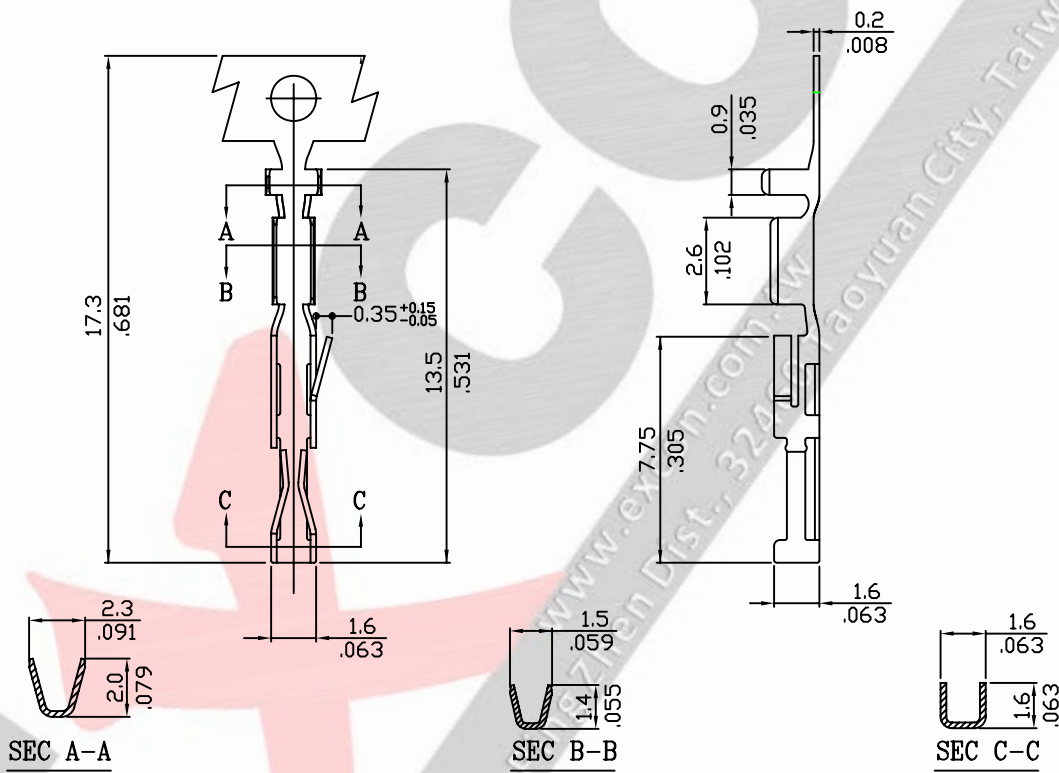
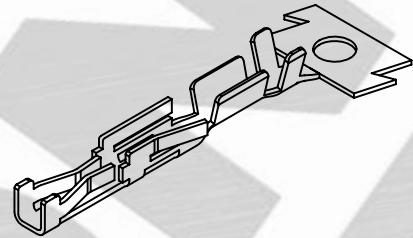

Ordering Information and Dimensions:

Part No.	Wire Range	Insulation O.D.	Material	Finish	Q'ty/reel
255100TC351	AWG#28~#22	0.9-1.6mm	phosphor	Tin pre-plated	20,000pcs
255100TC501	AWG#28~#22	0.9-1.6mm	phosphor	Gold flash	20,000pcs

Part Code Information:

2551-WW XX YY

① ② ③ ④

① Series Name

② Circuits Number
00 For Terminal

③ Product Type
TC=Terminal

④ Material/Finishing/Color
351=Phosphor,Tin Pre-Plated
501=Phosphor,Gold flash

Housing

1. Part No.: 2551xxHA203
2. Part Name: 2551 Housing
3. Material: PBT UL 94V0
4. Color: Black

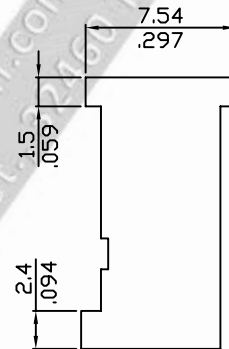
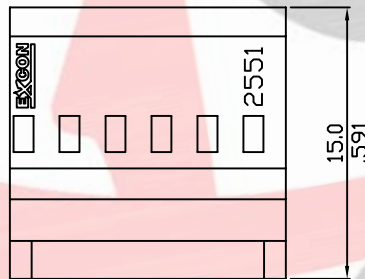
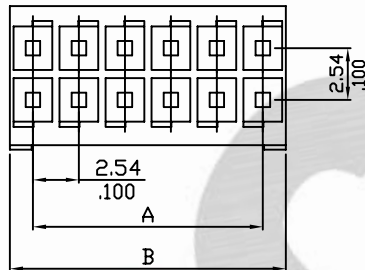
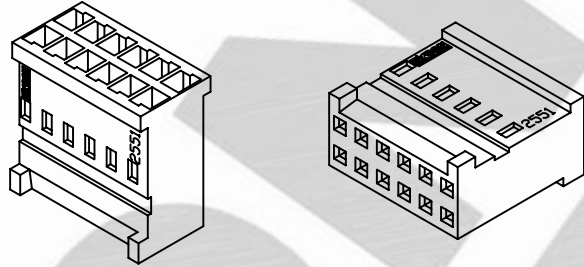

Ordering Information and Dimensions:

Part No.	Circuits	Dim A	Dim B	Part No.	Circuits	Dim A	Dim B
255106HA203	6	5.08(.200)	7.62(.300)	255122HA203	22	25.40(1.000)	27.94(1.100)
255108HA203	8	7.62(.300)	10.16(.400)	255124HA203	24	27.94(1.100)	30.48(1.200)
255110HA203	10	10.16(.400)	12.70(.500)	255126HA203	26	30.48(1.200)	33.02(1.300)
255112HA203	12	12.70(.500)	15.24(.600)	255128HA203	28	33.02(1.300)	35.56(1.400)
255114HA203	14	15.24(.600)	17.78(.700)	255130HA203	30	35.56(1.400)	38.10(1.500)
255116HA203	16	17.78(.700)	20.32(.800)	255132HA203	32	38.10(1.500)	40.64(1.600)
255118HA203	18	20.32(.800)	22.86(.900)	255134HA203	34	40.64(1.600)	43.18(1.700)
255120HA203	20	22.86(.900)	25.40(1.000)	255136HA203	36	43.18(1.700)	45.72(1.800)

Part Code Information:

2551-WW XX YYY

① ② ③ ④

① Series Name

② Circuits Number
06~36

③ Product Type
HA=Housing

④ Material/Finishing/Color
203=PBT 94V-0,Black

Wafer (Vertical type)

1. Part No.: 2551xxWV203
2. Part Name: 2551 Wafer
3. Material: PBT UL 94V0
Pin: Brass bronze, Tin plated
5. Color: Black

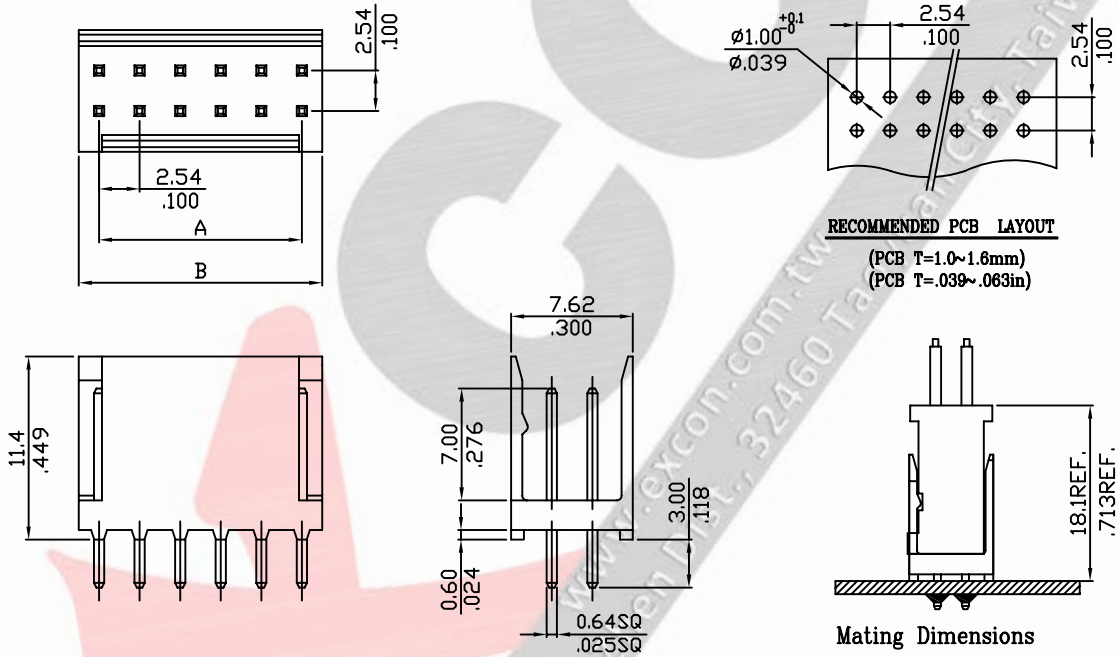
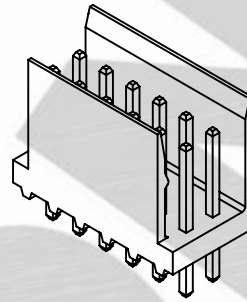

Ordering Information and Dimensions:

Part No.	Circuits	Dim A	Dim B	Part No.	Circuits	Dim A	Dim B
255106WV203	6	5.08(.200)	7.62(.300)	255122WV203	22	25.40(1.000)	27.94(1.100)
255108WV203	8	7.62(.300)	10.16(.400)	255124WV203	24	27.94(1.100)	30.48(1.200)
255110WV203	10	10.16(.400)	12.70(.500)	255126WV203	26	30.48(1.200)	33.02(1.300)
255112WV203	12	12.70(.500)	15.24(.600)	255128WV203	28	33.02(1.300)	35.56(1.400)
255114WV203	14	15.24(.600)	17.78(.700)	255130WV203	30	35.56(1.400)	38.10(1.500)
255116WV203	16	17.78(.700)	20.32(.800)	255132WV203	32	38.10(1.500)	40.64(1.600)
255118WV203	18	20.32(.800)	22.86(.900)	255134WV203	34	40.64(1.600)	43.18(1.700)
255120WV203	20	22.86(.900)	25.40(1.000)	255136WV203	36	43.18(1.700)	45.72(1.800)

Part Code Information:

2551-WW XX YYY

① ② ③ ④

① Series Name

② Circuits Number
06~36

③ Product Type
WV=Wafer (Vertical type)

④ Material/Finishing/Color
203=PBT 94V-0,Black

Wafer (Right angle type)

1. Part No.: 2551xxWR203
2. Part Name: 2551 Wafer
3. Material: PBT UL 94V0
Pin: Brass bronze, Tin plated
5. Color: Black

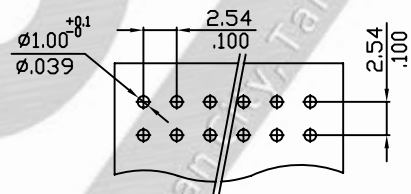
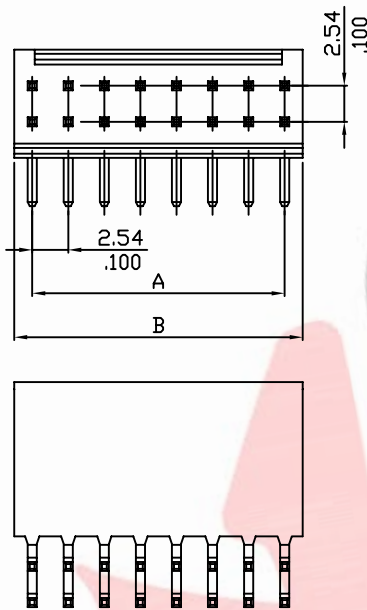
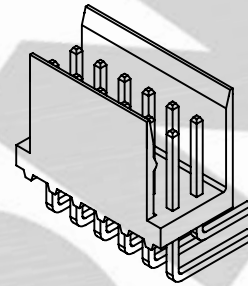

RECOMMENDED PCB LAYOUT

(PCB T=1.0~1.6mm)
(PCB T=.039~.063in)

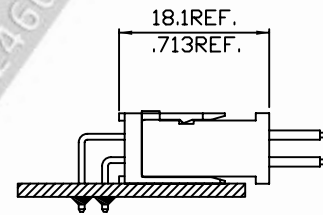
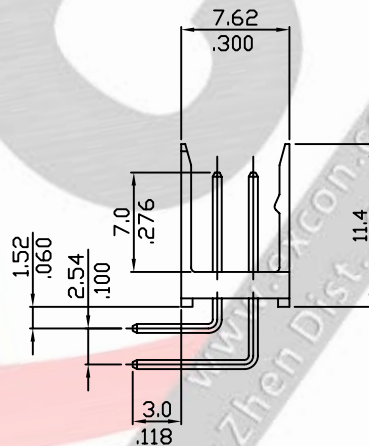

Mating Dimensions

Ordering Information and Dimensions:

Part No.	Circuits	Dim A	Dim B	Part No.	Circuits	Dim A	Dim B
255106WR203	6	5.08(.200)	7.62(.300)	255122WR203	22	25.40(1.000)	
255108WR203	8	7.62(.300)	10.16(.400)	255124WR203	24	27.94(1.100)	
255110WR203	10	10.16(.400)	12.70(.500)	255126WR203	26	30.48(1.200)	
255112WR203	12	12.70(.500)	15.24(.600)	255128WR203	28	33.02(1.300)	
255114WR203	14	15.24(.600)	17.78(.700)	255130WR203	30	35.56(1.400)	
255116WR203	16	17.78(.700)	20.32(.800)	255132WR203	32	38.10(1.500)	40.64(1.600)
255118WR203	18	20.32(.800)	22.86(.900)	255134WR203	34	40.64(1.600)	43.18(1.700)
			25.40(1.000)	255136WR203	36	43.18(1.700)	45.72(1.800)

Part Code Information:

2551-WW XX YYY

① ② ③ ④

① Series Name

② Circuits Number
06~36

③ Product Type

WR=Wafer (Right angle type)

④ Material/Finishing/Color

203=PBT 94V-0,Black